



EXETER CITY COUNCIL REGULAR MEETING AGENDA

April 28, 2026, 6:00 PM

City Hall, 137 North F Street
Exeter, California 93221

Mayor
Jacob Johnson
Mayor Pro Tem
Jeff Wilson
Council Members
Vicki Riddle
Frankie Alves
Bobby Lentz

Notice is hereby given that the Exeter City Council will hold a Regular Meeting on Tuesday, April 28, 2026, at 6:00 p.m. in person at Exeter City Hall located at 137 N. F St. in Exeter California, 93221.

Staff Reports related to items on the agenda are available on the City's website at <https://cityofexeter.ca.gov/> and available for viewing at City Hall.

6:00 p.m.

A. CALL TO ORDER CLOSED SESSION

B. PUBLIC COMMENTS REGARDING CLOSED SESSION MATTERS

Comments from the public are limited to items listed on the closed session matters (GC 54954.3a). Speakers will be allowed three (3) minutes. Please begin your comments by stating your name and providing your City of residence.

C. ADJOURN TO CLOSED SESSION PURSUANT TO GOVERNMENT CODE SECTION(S)

1. GC 549.56.9(d)(4) – Conference with Legal Counsel
Re Potential Initiation of Litigation
2. GC 54956.9(d)(1) – Conference with Legal Counsel
Re Existing Litigation
City of Exeter v. Bumgarner, Tulare County Superior Court No. VCU323368
City of Exeter v. Clark, et al., Tulare County Superior Court No. VCU292152
3. GC 54956.9(d)(2) – Conference with Legal Counsel
Re Significant Exposure to Litigation – One (1) Case facts not known to potential plaintiff(s)
4. GC 54956.9 – Consideration of Liability Claims
Claimant: Rosalinda Ruiz
Claimed Against: City of Exeter

5. GC 54957(b)(1) – Public Employee Annual Performance Evaluation
Title: City Administrator
Title: City Attorney

7:00 p.m.

D. CALL TO ORDER REGULAR SESSION

E. INVOCATION

F. PLEDGE OF ALLEGIANCE

G. PUBLIC COMMENTS

This is the time for citizens to comment on subject matters that are not on the agenda that are within the jurisdiction of the Exeter City Council. In compliance with public meeting laws, Council cannot discuss topics that are not included on the published agenda. This is also the time for citizens to comment on items listed on the Consent Calendar or to request an item from the Consent Calendar be pulled for discussion purposes. Public comments related to all pulled Consent Calendar Items and all Individual Business or Public Hearing Items that are listed on this agenda will be heard at the time that item is discussed or at a time the Public Hearing is opened for comment.

In fairness to all who wish to speak tonight, comments shall be limited to five (5) minutes for each individual, ten (10) minutes for an individual representing a group, and thirty (30) minutes overall for the entire public comment period, unless otherwise indicated by the Mayor. Although not required, speakers are asked to begin their comments by stating their name and city of residence.

H. SPECIAL PRESENTATIONS

1. Tulare County Fire Department Update
Presented by Chief Charlie Norman, Tulare County Fire Chief

I. CONSENT CALENDAR

Items listed under the Consent Calendar are considered routine and will be enacted by one motion. There will be no separate discussion of these matters unless a request is made and then the item will be removed from the Consent Calendar to be discussed and voted upon by a separate motion.

1. Approval of the April 14, 2026, Regular Meeting Minutes (pp. 5 – 10)
2. Approval of the Payment of Bills for April 17, 2026 (pp. 11 – 17)
3. Approval of Payroll for the Period of March 22, 2026, through April 5, 2026 (pp. 18 – 25)

4. Approval of a Street Closure of E Street between East Cedar Street and Clarence Avenue on May 16, 2026, from 4:00 p.m. to 7:00 p.m. for a Private Fundraising Event hosted by the Center for Art, Culture, and History Exeter (CACHE), and Approval of a Street Closure Fee Waiver, Subject to Conditions of Approval (pp. 26 – 31)
5. Schedule a Special joint City Council Meeting with the Exeter Unified School District Board of Trustees on May 6, 2026 (pp. 32 – 33)
6. Adoption of **Resolution No. 2026-12**, A Resolution of the City Council of the City of Exeter, Approving the Filing of a Notice of Exemption Pursuant to the California Environmental Quality Act (CEQA) for the Exeter Test Well Drilling and Sampling #2 Project (pp. 34 – 38)
7. Receive and File the City Treasurer’s Report for December 2025 (pp. 39 – 42)
8. Approval of a Request for the Exeter Kiwanis Club to Host a Special Event Celebrating 100 Years of the Exeter City Park Wading Pool and Dedication Wading Pool Improvements on June 7, 2026, and Approval of a Special Event Fee Waiver (pp. 43 – 47)
9. Approval of a Special Event and Facility Use Request by the Exeter Golf Course for a Golf Cart Parade on July 4, 2026, and Approval of a Special Event Fee Waiver (pp. 48 – 52)
10. Approval of a Special Event and Facility Use for the E250 Community Celebration Festivities at City Park on July 4, 2026, and Approval of a Special Event Fee Waiver (pp. 53 – 57)
11. Approval of the Selection of American Emergency Products (AEP) for Police Vehicle Outfitting Services and Authorize the City Administrator or their Designee to Execute all Necessary Documents (pp. 58 – 102)

J. INDIVIDUAL BUSINESS ITEMS

Comments related to Individual Business and Public Hearing Items are limited to three (3) minutes per speaker, for a maximum of 30 minutes per item. The Mayor may reasonably limit or extend the public comment period to preserve the Council's interest in conducting efficient, orderly meetings.

1. Consideration of Proposed Active Transportation Project on South E Street and Approval of **Resolution No. 2026-13**, A Resolution of the City Council of the City of Exeter, Authorizing the City Administrator to Utilize up to \$2,000,000 in Measure R Transit/Bike/Environmental Mitigation Funds Programmed to the City of Exeter for the E Street Active Transportation and ADA Improvements Project and Authorizing the City Engineer to Commence Design of the Project (pp. 103 – 109)
Presented by Javier Andrade, City Engineer
2. Consider Adoption of **Resolution No. 2026-14**, A Resolution of the City Council of the City of Exeter, Appointing a CalPERS Retired Annuitant to Serve as a Records Clerk on a Temporary Basis (pp. 110 – 121)
Presented by Francesca Quintana, City Clerk/Human Resources Manager

K. CITY COUNCIL ITEMS OF INTEREST

L. CITY ADMINISTRATOR/DEPARTMENT COMMENTS

M. REGULAR MEETING ADJOURNMENT

State of California)
County of Tulare) ss.
City of Exeter)

I declare under penalty of perjury that I am employed by the City of Exeter, in the Administrator’s Office; and that I posted this Agenda on the bulletin board outside of City Hall 137 N. F St. Exeter CA 93221 on April 24, 2026, and online on the [City of Exeter website](#).



Francesca Quintana, City Clerk

In compliance with the Americans with Disabilities Act, and the California Ralph M. Brown Act, if you need special assistance to participate in this meeting, or to be able to access this agenda and documents in the agenda packet, please contact the City Clerk (559)592-9244. Notification prior to the meeting will enable the City to make reasonable arrangements to ensure accessibility to this meeting and/or provision of an appropriate alternative format of the agenda and documents in the agenda packet. (28 CFR 35.102-35. 104 ADA Title II).

Materials related to an item on this Agenda submitted to the legislative body after distribution of the agenda packet are available for public inspection at City of Exeter, Administration Office 100 N. C St., Exeter CA 93221 during normal business hours.



**EXETER CITY COUNCIL
REGULAR MEETING AGENDA
ACTION MINUTES**

April 14, 2026, 6:30 PM
City Hall, 137 North F Street
Exeter, California 93221

Mayor
Jacob Johnson
Mayor Pro Tem
Jeff Wilson
Council Members
Vicki Riddle
Frankie Alves
Bobby Lentz

Notice is hereby given that the Exeter City Council will hold a Regular Meeting on Tuesday, April 14, 2026, at 6:30 p.m. in person at Exeter City Hall located at 137 N. F St. in Exeter California, 93221.

Staff Reports related to items on the agenda are available on the City's website at <https://cityofexeter.ca.gov/> and available for viewing at City Hall.

6:30 p.m.

A. CALL TO ORDER CLOSED SESSION

Mayor called the closed session to order at 6:30 PM.

B. PUBLIC COMMENTS REGARDING CLOSED SESSION MATTERS

No public comments were presented.

C. ADJOURN TO CLOSED SESSION PURSUANT TO GOVERNMENT CODE SECTION(S)

1. GC 54957.6 – Conference with Labor Negotiations
Agency Negotiator: Shelline Bennett and Jason Ridenour
Employee Groups: All Represented and Unrepresented Employees

7:00 p.m.

D. CALL TO ORDER REGULAR SESSION

Mayor Johnson called the regular session to order at 07:00 p.m. City Attorney Lew noted for the record that there was no reportable action taken out of closed session.

E. INVOCATION

Led by Mayor Johnson.

F. PLEDGE OF ALLEGIANCE

Led by Council Member Alves.

G. PUBLIC COMMENTS

Public comment was provided by Sherri Wilson, who introduced Shannon Schroth as the new Executive Director of the Chamber of Commerce.

H. SPECIAL PRESENTATIONS

1. Employee of the Quarter Award (pp. 5 – 6)
Presented by Mayor Johnson

Mayor Johnson presented the employee of the Quarter Award to Deputy City Clerk/Personnel Officer.

I. CONSENT CALENDAR

Items listed under the Consent Calendar are considered routine and will be enacted by one motion. There will be no separate discussion of these matters unless a request is made and then the item will be removed from the Consent Calendar to be discussed and voted upon by a separate motion.

1. Approval of the March 24, 2026, Regular Meeting Minutes (pp. 7 – 11)
2. Approval of the Payment of Bills for March 20, 2026, March 26, 2026, and April 3, 2026. (pp. 12 – 27)
3. Approval of Payroll for the Period of March 9, 2026, through March 22, 2026 (pp. 28 – 43)
4. Adoption of **Resolution No. 2026-11**, A Resolution of the City Council of the City of Exeter, Approving the Submittal of a Program Income-only Application to the California Department of Housing and Community Development HOME Program for First-Time Homebuyer and Owner-Occupied Rehabilitation Programs in an amount of \$736,537 in Current Funds Along with any Additional Future Program Income (pp. 44 – 49)
5. Approval of a Community Beautification Project Request for Painting Multiple Fire Hydrants with a Patriotic Theme (pp. 50 – 67)
6. Approval of a Request from We Fit Boot Camp and Gym to Host a Car Show Requiring a Street Closure on Saturday April 25, 2026 (pp. 68 – 76)
7. Consider Authorizing the Director of Public Works to Issue an Encroachment Permit for the Use of up to Six (6) Parking Spaces by the Exeter Chamber of Commerce and Harvest Wealth, along with a Permit Fee Waiver for a Drive Through Document Shredding Event (pp. 77 – 82)
8. Consideration of Project Acceptance, Release of Retention Funds and Authorize Filing of a Notice of Completion (NOC) for the Police Department and Administration Building Remodel Project with Sierra Range Construction (pp. 83 – 89)
9. Confirmation of Employment Agreement with Janie Rodriguez for the Position of Finance Director and Authorize the City Administrator to Execute the Agreement (pp. 90 – 98)

10. Approval of a Street Closure for a City-Sponsored Independence Day 5K Run and Community Pancake Breakfast (pp. 99 – 103)

City Attorney Lew noted for the record regarding Item I.9 that, consistent with Brown Act requirements, the proposed salary and benefits for the Finance Director align with the adopted salary schedule. She further stated that the only distinction from other director contracts is the provision allowing the candidate to carry over accrued sick leave from their current employer.

Approval of Consent Calendar							
1 st	2 nd	Result	JONHSON	WILSON	ALVES	RIDDLE	LENTZ
ALVES	LENTZ	(5-0)	AYE	AYE	AYE	AYE	AYE

J. INDIVIDUAL BUSINESS ITEMS

Comments related to Individual Business and Public Hearing Items are limited to three (3) minutes per speaker, for a maximum of 30 minutes per item. The Mayor may reasonably limit or extend the public comment period to preserve the Council's interest in conducting efficient, orderly meetings.

1. Conduct Second Reading and Adopt **Ordinance No. 719**, an Ordinance of the City Council of the City of Exeter Adding Chapter 15.56 to Title 15 of the Exeter Municipal Code to Establish an Expedited Permitting Process for Electric Vehicle Charging Stations Consistent with California Government Code Section 65850.7 (pp. 104 – 116)
Presented by Julia Lew, City Attorney

City Attorney provided a report for the Council and members of the public.

No public comment was received.

City Attorney provided second reading of the Ordinance by Title only.

Second Reading and Adopt Ordinance No. 719, an Ordinance of the City Council of the City of Exeter Adding Chapter 15.56 to Title 15 of the Exeter Municipal Code to Establish an Expedited Permitting Process for Electric Vehicle Charging Stations Consistent with California Government Code Section 65850.7							
1 st	2 nd	Result	JONHSON	WILSON	ALVES	RIDDLE	LENTZ
WILSON	RIDDLE	(5-0)	AYE	AYE	AYE	AYE	AYE

2. Consider Approval of Request from the Exeter Lions Club to Sponsor the 2026 and 2027 Exeter Lions Independence Celebration (pp. 117 – 120)
Presented by Jason Ridenour, City Administrator

Mayor Johnson and Council Member Riddle recused themselves from the item due to a conflict of interest and stepped down from the dais, taking no part in the discussion or vote.

City Administrator provided a report for the Council and members of the public.

Public comment was received from Andrew Rodriguez, who spoke about the event and expressed appreciation to the Council and City for considering the partnership.

Approval of Request from the Exeter Lions Club to Sponsor the 2026 and 2027 Exeter Lions Independence Celebration.							
1 st	2 nd	Result	JONHSON	WILSON	ALVES	RIDDLE	LENTZ
ALVES	LENTZ	(3-0)	ABSTAIN	AYE	AYE	ABSTAIN	AYE

Mayor Johnson and Council Member Riddle resumed their seats at the dais after the conclusion of this item.

3. Consider Authorizing the Mayor to Sign Letters of Support for SB 1018, SB 1217, SB 1277, and SB 1373 (pp. 121 – 152)
Presented by Jason Ridenour, City Administrator

City Administrator provided a report for the Council and members of the public.

Mayor opened the item up for public comment. No public comments were received.

Authorizing the Mayor to Sign Letters of Support for SB 1018, SB 1217, SB 1277, and SB 1373.							
1 st	2 nd	Result	JONHSON	WILSON	ALVES	RIDDLE	LENTZ
WILSON	RIDDLE	(5-0)	AYE	AYE	AYE	AYE	AYE

4. Consider Approval of Landscape Improvement Projects for the Blossom Estates Lighting and Landscape Maintenance District (LLMAD) (pp. 153 – 157)
Presented by Zachary Boudreaux, Public Works Director

Public Works Director provided a report for the Council and members of the public.

Mayor opened the item up for public comment. No public comments were received.

Approval of Landscape Improvement Projects for the Blossom Estates Lighting and Landscape Maintenance District (LLMAD).							
1 st	2 nd	Result	JONHSON	WILSON	ALVES	RIDDLE	LENTZ
WILSON	RIDDLE	(5-0)	AYE	AYE	AYE	AYE	AYE

5. Consider Award of Contract to Perform a City-Wide Rate Study and Authorize the City Administrator or Designee to Execute Necessary Contracts and Documents Related to the Rate Study (pp. 158 – 192)

Presented by Zachary Boudreaux, Public Works Director

Public Works Director provided a report for the Council and members of the public.

Mayor opened the item up for public comment. No public comments were received.

Award of Contract to Perform a City-Wide Rate Study to QK Inc. and Authorize the City Administrator or Designee to Execute Necessary Contracts and Documents Related to the Rate Study.							
1 st	2 nd	Result	JONHSON	WILSON	ALVES	RIDDLE	LENTZ
JOHNSON	ALVES	(5-0)	AYE	AYE	AYE	AYE	AYE

K. CITY COUNCIL ITEMS OF INTEREST

Council Member Alves reported attending a San Joaquin Valley Air Pollution Control District Committee meeting and the Citywide Yard Sale.

Mayor Pro Tem Wilson reported attending the Farmers Market and expressed condolences to the family of fallen Sheriff’s Deputy Hoppert.

Council Member Riddle reported attending the Farmers Market and hosting an E250 Committee meeting, which was also attended by the City Engineer.

Council Member Lentz had no report.

Mayor Johnson reported attending and enjoying the Citywide Yard Sale and expressed condolences to Deputy Hoppert’s family.

L. CITY ADMINISTRATOR/DEPARTMENT COMMENTS

City Administrator, Public Works Director, Chief of Police, City Attorney and City Clerk/Human Resources Manager provided comments/reports.

M. REGULAR MEETING ADJOURNMENT

Mayor adjourned the meeting at 8:02 p.m.

Francesca Quintana, City Clerk



Agenda Item Staff Report

Agenda Item Number:

I.2.

Meeting Date:

April 28, 2026

Wording for Agenda:

Approval of the Payment of Bills for April 17, 2026.

Submitting Department:

Administration

Contact Name:

Jason Ridenour, City Administrator

For action by:

City Council

Regular Session:

Consent Calendar

Regular Item

Public Hearing

Review:

City Administrator
(Initials Required)

J.R

Department Recommendation:

Staff recommends that the City Council approve the payment of bills in the following amount.

- \$481,698.96 dated April 17, 2026.

Summary:

The Finance Department has reviewed and compiled invoices and expenses for city operations for approval by the City Council, which are summarized and attached to this report. This action authorizes the disbursement of funds for routine and approved expenditures necessary to continue city services.

Background:

The payment of bills is a recurring action presented to the City Council to ensure transparency and fiscal oversight of city expenditures. The item reflects payments made for various city services, supplies, utilities, and obligations incurred in the normal course of business. All bills have been reviewed by the Finance Department and are within budgeted appropriations.

Fiscal Impact:

- Total amount: \$481.698.96 dated April 17, 2026.
- Funding sources: Various city departmental budgets
- Budget implications: All payments are within the approved Fiscal Year 2025–2026 budget. No additional appropriations are necessary.

Prior City Council Actions:

The City Council routinely approves payment of bills during regular meetings. This item is part of the standard financial reporting and authorization process.

Attachments:

- Payments for Publication Report dated April 17, 2026.

Recommended motion to be made by the City Council:

I move to approve the payment of bills in the amount of \$481,698.96 dated April 17, 2026.

Report Selection:

Run Group... 041726 Comment... CHECK RUN 04/17/2026

Approval Date for Report..... 04 17 2026

Payments Through Date..... 04 17 2026

Cutoff Amount to be Used..... 0000000

RUN GROUP... 041726 COMMENT... CHECK RUN 04/17/2026

DATA-JE-ID DATA COMMENT

D-04172026-896 CHECK RUN 04/17/2026

Run Instructions:

Jobq	Banner	Copies	Form	Printer	Hold	Space	LPI	Lines	CPI	CP	SP	RT
L		01		LASERHP4	Y	S	6	066	10			

Approved on 4/17/2026 for Payments Through 4/17/2026

Vendor Name	Description	Amount
A.R.E AUTO PARTS INC.	DELO GREASE	1,334.92
A-C ELECTRIC COMPANY	TRAFFIC LIGHT BLMNT/VISA	466.00
ABLE INDUSTRIES, INC	3/26 MAINT VISALIA RD	652.50
AFLAC	FEB 2026 AFLAC	3,065.38
AT&T	MAR 2026 LIVESCAN	424.80
AVILA GENERAL ENGINEERING CO	DEMO-310 & 314 FIREBAUGH	48,024.81
CAL APPAREL INC	2026 TBALL SOFTBALL HATS	12,132.36
CALIFORNIA BUSINESS MACHINES	ADMIN 3/1-3/31/26 OVERAG	789.24
CARDOZA/ PAUL	REP MAINLINE/ZONELINE-GV	6,934.21
CENTRAL CAL WATERWORKS, INC	CPO APR 2026 WTR	17,682.46
CIVICA LAW GROUP, APC	MAR 528 D ST CODE ENFORC	4,110.70
CONSENSUS CLOUD SOLUTIONS	EFAX APR MAINTENANCE FEE	174.23
COUNTY OF TULARE	NOV MAIL MONTHLY	22,620.54
DATA TICKET, INC	FEB CITATION PROCESSING	160.65
DEPT OF JUSTICE	FEB BLOOD ALCOHOL	70.00
DIVISION OF STATE ARCHITECT	JAN-MAR 26 \$4 DSA FEE	101.20
EMPLOYER DRIVEN SOLUTIONS	MAY 2026 COVERAGE	925.00
EWING IRRIGATION PRODUCTS INC	HUNTER 3/4 ULTRA 4IN	2,437.77
EXETER MERCANTILE CO.	SPLY WTRH TR-PD/ADMIN	436.01
EXETER MOTORS, INC.	E11-MOTOR AND FAN	1,987.62
FASTENAL COMPANY	3" YELLOW CAUTION TAPE	220.02
FRESNO OXYGEN	"B" ACET CYCLS	52.75
GAR BENNETT LLC	GLY STAR PLUS/AXILL SOLU	2,134.52
GIEFER/ MICHAEL	GIEFER ADPP MAY 2026	4,461.77
INTERNATIONAL CYBERNETICS CO	STREET PAVEMENT ANALYSIS	3,200.00
JACK GRIGGS INC	MAR 2026 GAS	11,211.40
KAWEAH PUMP, INC.	WELL 10 REPR-AIR LIFT TO	31,610.86
KAWEAH WATER FOUNDATION	2026 ANNUAL FOUNDAT CONT	6,000.00
KRC SAFETY CO INC.	3/27-4/3/26 PCMS BOARDS	2,150.45
LEAF CAPITAL FUNDING LLC	ADMIN-APR 2026 KYOCERA	477.21
MID VALLEY DISPOSAL, LLC	3/24/26 40Y EXCHANGE	450.01
MINERAL KING PUBLISHING INC	11/19 PH ORDINANCE 717	267.30
NHA ADVISORS, LLC	2020 WTR BND-CONT COMPLI	3,750.00
PACE SUPPLY CORP.	6 FIRE HYDRANT PURCHASE	26,261.32
PENA'S DISPOSAL INC	PD MAR 2026 SHRED	193.21
PROACTIVE ENVIRONMENTAL	MEGA MONSOON PUMP	673.60
PROVOST & PRITCHARD	MAR 2026 TOOLEVILLE	2,470.68
QUINTANA/ FRANCESCA	CSJVRMA-MILE REIMBURSEME	60.03
SAN JOAQUIN VALLEY APCD	26/27 PERMITS-655 W VINE	314.00
SERVIAM BY WRIGHT LLP	FEB 2026-333 PALM	1,128.90
SIMMONS TIRE SERVICE	LP 1469269 REAR ROTORS	5,743.34
SOUTHERN CALIFORNIA EDISON	7269-3/1/26-3/31/26	9,293.37
SOUTHERN CALIFORNIA GAS CO.	7144-3/1/26-4/1/26	16.02
SYNERGIZED HR LLC	CITY CLASS & COMP STUDY	21,800.00
TELSTAR INSTRUMENTS	INSTALL SCADA SYSTEM	221,068.00
TRANSUNION RISK & ALTERNATIVE	MAR 2026 PERSON SEARCH	100.00
ULINE	2.5 GAL PLASTIC GAS CAN	139.85
UNIFIRST CORPORATION	3/24/26 UNIFORM CLEANING	850.88

Approved on 4/17/2026 for Payments Through 4/17/2026

Vendor Name	Description	Amount
UNIVAR SOLUTIONS USA INC	APR SOD HYPO WELL 13	749.07
WEST COAST TOW	TIRE SERVICE-LIC#1520582	320.00
	Final Totals...	481,698.96

**

TOTAL NUMBER OF RECORDS PRINTED 318

Payments for Publication

FUND RECAP:

FUND	DESCRIPTION	DISBURSEMENTS
104	GENERAL FUND	53,474.17
105	WATER FUND	211,491.17
106	SANITATION FUND	3,821.61
107	SEWER FUND	179,053.88
109	GAS TAX FUND	9,759.37
113	TRANSPORTATION FUND	3,200.00
121	INSURANCE FUND	925.00
131	MEASURE R	652.50
140	LANDSCAPE AND LIGHTING DISTR	6,934.21
141	MEASURE P	12,387.05
TOTAL ALL FUNDS		481,698.96

BANK RECAP:

BANK	NAME	DISBURSEMENTS
BANK	BANK OF THE SIERRA	481,698.96
TOTAL ALL BANKS		481,698.96



Agenda Item Staff Report

Agenda Item Number:

I.3.

Meeting Date:

April 28, 2026

Wording for Agenda:

Approval of Payroll for the Period of March 22, 2026, through April 5, 2026.

Submitting Department:

Administration

Contact Name:

Jason Ridenour, City Administrator

For action by:

City Council

Regular Session:

Consent Calendar

Regular Item

Public Hearing

Review:

City Administrator
(Initials Required)

J.R.

Department Recommendation:

Staff recommend that the City Council approve payroll for the period of March 9, 2026, to March 22, 2026, in the following amounts.

- \$81,139.10 for March 22, 2026, through April 5, 2026, period with a check date of April 10, 2026.

Summary:

This item requests City Council approval of payroll expenditures incurred during the pay period of March 22, 2026, through April 5, 2026. Timely approval ensures the city remains compliant with labor obligations and continues uninterrupted compensation to employees.

Background:

The City of Exeter processes payroll on a biweekly basis. City Council approval is required for each payroll cycle as part of the city's fiscal oversight procedures. The current payroll covers all regular full-time, part-time, and temporary employees for the specified pay period.

Fiscal Impact:

- Total payroll amount: \$81,139.10 (for March 22, 2026, through April 5, 2026, payroll period period)
- Funding source: Approved departmental salary budgets

- Budget implications: Payroll is within the adopted Fiscal Year 2025-2026 budget; no additional funds are required.

Prior City Council Actions:

Payroll approval is a standing item brought to the City Council regularly to ensure accountability and continuity of operations.

Attachments:

- Payroll Register for the period March 22, 2026, through April 5, 2026.

Recommended motion to be made by the City Council:

I move to approve payroll for the period of March 22, 2026, through April 5, 2026, in the amount of \$81,139.10.

PERIOD 1 DATING 3/23/2026- 4/05/2026 CHECK DATE 4/10/2026
 DIRECT DEPOSIT IS TURNED ON

CHECK NUMBER	CHECK AMOUNT	EMPLOYEE/BANK/VENDOR NAME	CODE	CHECK SEQ
1822	63.69	CA STATE DISBURSEMENT UN	2	1 VENDOR CHECK
1823	758.24	FRANCHISE TAX BOARD	8	1 VENDOR CHECK
1824	46.17	JOHNSON/JACOB	739	1
1825	993.85	CREECH/JACE W	777	1

TOTALS FOR CHECK FORM: CHEK		COUNTS
NEGOTIABLE CHECKS		
1,040.02	*EMPLOYEE CHECKS	2
821.93	*VENDOR CHECKS	2
0.00	*BANK CHECKS	0
1,861.95	**TOTAL NEGOTIABLE CHECKS	4
OTHER CHECKS		
0.00	*MANUAL CHECKS	0
0.00	*CANCELLED CHECKS	0
1,861.95	**TOTAL FOR CHECK FORM	
NON-NEGOTIABLE CHECKS		
0.00	*DIRECT DEPOSIT STUBS	0
0.00	*VENDOR DIR DEP STUBS	0

PERIOD 1 DATING 3/23/2026- 4/05/2026 CHECK DATE 4/10/2026
DIRECT DEPOSIT IS TURNED ON

CHECK NUMBER	CHECK AMOUNT	EMPLOYEE/BANK/VENDOR NAME	CODE	CHECK SEQ
54761	156.00	CLOCEA	4	1 VENDOR STUB ONLY
54762	308.00	EXETER POLICE OFFICER AS	3	1 VENDOR STUB ONLY
54763	192.94	EXETER POLICE OFFICER AS	3A	1 VENDOR STUB ONLY
54764	2,245.57	ARIAS/CHRISTINA	730	1 STUB ONLY
54765	2,819.91	QUINTANA FRANCESCA N	742	1 STUB ONLY
54766	4,709.32	RIDENOUR/JASON CHARLES	763	1 STUB ONLY
54767	1,481.25	CARTER/AMY JO	502	1 STUB ONLY
54768	698.28	HERNANDEZ/XOCHITL	306	1 STUB ONLY
54769	1,549.05	MILLER/CATHEY RENE	734	1 STUB ONLY
54770	1,488.11	RAMOS LEON/YOSENIA	776	1 STUB ONLY
54771	1,862.43	TOBIAS/ANTHONY JORDAN	746	1 STUB ONLY
54772	639.89	VEGA/ASHLEY MAKAYLA	753	1 STUB ONLY
54773	2,130.71	BROWN/ANDREW EUGENE	762	1 STUB ONLY
54774	2,040.47	BRYANT/EZRA JOSEPH	752	1 STUB ONLY
54775	1,710.73	CARRETERO/VANESSA	402	1 STUB ONLY
54776	1,662.90	GREEN GROVE/BRAYDEN TAY	767	1 STUB ONLY
54777	3,366.25	HEINKS/RYAN DAVID	765	1 STUB ONLY
54778	1,662.90	HERNANDEZ/ANDY	780	1 STUB ONLY
54779	1,322.11	HILL/HANNAH GRACE	747	1 STUB ONLY
54780	2,012.91	LINARES/FRANCISCO JR	772	1 STUB ONLY
54781	2,810.78	MAGANA MARTINEZ JOEL	773	1 STUB ONLY
54782	3,449.46	MOORE/ROBERT HARRY	764	1 STUB ONLY
54783	1,726.91	MORALES/SKYLEENA ROSE	779	1 STUB ONLY
54784	1,489.77	PRIDEAUX/TRACI	448	1 STUB ONLY
54785	4,363.36	SCHIMPF/ROBERT BRIAN	766	1 STUB ONLY
54786	2,457.03	SHIELDS/ZION	708	1 STUB ONLY
54787	2,239.85	VILLARREAL/ISIDRO	707	1 STUB ONLY
54788	1,887.44	ALDRIDGE/GARY	618	1 STUB ONLY
54789	3,548.17	BOUDREAUX/ZACHARY MICHA	756	1 STUB ONLY
54790	291.52	GOLDSTROM/NORMAN	629	1 STUB ONLY
54791	1,845.52	HUGGINS/KYLE AARON	621	1 STUB ONLY
54792	2,512.36	MILLAN/MARCUS	622	1 STUB ONLY
54793	1,680.11	RIVERA/RYAN	733	1 STUB ONLY
54794	741.83	WENDT/EDDIE	626	1 STUB ONLY
54795	1,607.49	GARVER/ELIJAH	712	1 STUB ONLY
54796	1,808.88	ARROYO/MARIE	623	1 STUB ONLY
54797	1,528.31	QUIROZ/PATRICK P	512	1 STUB ONLY
54798	2,075.64	RAMIREZ/GABRIEL GRACILI	761	1 STUB ONLY
54799	2,182.34	RAMIREZ/JUAN	608	1 STUB ONLY
54800	3,038.72	HIFNER/CHRISTOPHER	736	1 STUB ONLY
54801	501.66	RUBIO/IVAN	750	1 STUB ONLY
54802	436.42	MCCOOL/JASPER JAX	785	1 STUB ONLY
54803	993.85	RANGEL/JOSE A	775	1 STUB ONLY

PERIOD 1 DATING 3/23/2026- 4/05/2026 CHECK DATE 4/10/2026
DIRECT DEPOSIT IS TURNED ON

CHECK NUMBER	CHECK AMOUNT	EMPLOYEE/BANK/VENDOR NAME	CODE	CHECK SEQ
-----------------	-----------------	------------------------------	------	--------------

TOTALS FOR CHECK FORM: STUB

NEGOTIABLE CHECKS			COUNTS
0.00	*EMPLOYEE CHECKS		0
0.00	*VENDOR CHECKS		0
0.00	*BANK CHECKS		0
0.00	**TOTAL NEGOTIABLE CHECKS		0

OTHER CHECKS

0.00	*MANUAL CHECKS		0
0.00	*CANCELLED CHECKS		0
0.00	**TOTAL FOR CHECK FORM		

NON-NEGOTIABLE CHECKS

78,620.21	*DIRECT DEPOSIT STUBS		40
656.94	*VENDOR DIR DEP STUBS		3

PERIOD 1 DATING 3/23/2026- 4/05/2026 CHECK DATE 4/10/2026

EMPLOYER CODE	FUND CODE	HOME TOTALS	WORKED TOTALS	WORKED DIR DEP
1	104	66,100.56	47,339.75	47,293.58
1	105	7,595.17	14,055.76	14,055.76
1	106	.00	1,038.45	1,038.45
1	107	.00	10,601.15	10,028.70
1	121	.00	1,805.52	1,805.52
1	141	5,964.50	4,819.60	4,398.20

NOTE--"HOME TOTALS" CHECK AMOUNT CAN BE RECONCILED TO THE FIGURES
 OF THE FOLLOWING REPORTS:

- #1 CALCULATION TOTALS BY HOME FUND (NET PAY + REIMB. EXP.)
- #2 PAYROLL REGISTER (CHECK AMOUNT)

NOTE--"WORKED TOTALS" CHECK AMOUNT CAN BE RECONCILED TO THE FIGURES
 OF THE FOLLOWING REPORTS:

- #1 CALCULATION TOTALS BY FUND WORKED (NET PAY + REIMB. EXP.)
- #2 LABOR DISTRIBUTION (NET PAY + REIMB. EXP.)

PERIOD 1 DATING 3/23/2026- 4/05/2026 CHECK DATE 4/10/2026

EMR CODE	FUND CODE	DEPT CODE	HOME TOTALS	FULL EMPLOYEE	PART EMPLOYEE	TEMP COUNTS	FEMALE
1	104	401 CITY COUNCIL	46.17		1		
1	104	402 ADMINISTRATION	9,774.80	3			2
1	104	403 FINANCE	7,719.01	4	1	1	5
1	104	421 POLICE	34,446.14	15			4
1	104	431 STREET	12,506.95	5	2		
1	104	471 RECREATION	1,607.49	1			
1	105	461 WATER	7,595.17	4			1
1	141	421 POLICE	3,038.72	1			
1	141	471 RECREATION LEADER	501.66	1			
1	141	472 PARKS	2,424.12	3			
TOTAL			79,660.23	37	4	1	12

PERIOD 1 DATING 3/23/2026- 4/05/2026 CHECK DATE 4/10/2026

EMPLOYER CODE	FUND CODE	HOME TOTALS	WORKED TOTALS	WORKED DIR DEP
------------------	--------------	----------------	------------------	-------------------

GRAND TOTALS

NEGOTIABLE CHECKS	COUNTS
1,040.02 *EMPLOYEE CHECKS	2
821.93 *VENDOR CHECKS	2
0.00 *BANK CHECKS	0
1,861.95 ***TOTAL NEGOTIABLE CHECKS	4

OTHER CHECKS

0.00 *MANUAL CHECKS	0
0.00 *CANCELLED CHECKS	0

1,861.95 ***GRAND TOTAL

NON-NEGOTIABLE CHECKS

78,620.21 *DIRECT DEPOSIT STUBS	40
656.94 *VENDOR DIR DEP STUBS	3

79,277.15 **TOTAL NON-NEGOTIABLE CHECKS 43

NEGOTIABLE CHECKS/NON-NEGOTIABLE CHECKS

1,040.02 *EMPLOYEE CHECKS	2
821.93 *VENDOR CHECKS	2
0.00 *BANK CHECKS	0
78,620.21 *DIRECT DEPOSIT STUBS	40
656.94 *VENDOR DIR DEP STUBS	3

81,139.10 ***TOTAL NEGOTIABLE & NON-NEGOT 47

0.00 *OTHER CHECKS 0

81,139.10 ***TOTAL NEG, NON-NEG, OTHER CHECKS

TOTAL SEQ 1 FEMALES 12



Agenda Item Staff Report

Agenda Item Number:

I.4.

Meeting Date:

April 28, 2026

Wording for Agenda:

Approval of a Street Closure of E Street between East Cedar Street and Clarence Avenue on May 16, 2026, from 4:00 p.m. to 7:00 p.m. for a Private Fundraising Event hosted by the Center for Art, Culture, and History Exeter (CACHE), and Approval of a Street Closure Fee Waiver, Subject to Conditions of Approval.

Submitting Department:

Public Works

Contact Name:

Marie Arroyo, Senior Administrative Assistant

Department Recommendation:

Staff recommends the City Council approve a street closure of E Street between East Cedar Street and Clarence Avenue for a private fundraising event hosted by the Center for Art, Culture, and History – Exeter (CACHE), beginning at 4:00 p.m. on May 16, 2026, and ending at 7:00 p.m., along with a street closure fee waiver of \$103, subject to the conditions of approval.

Background & Summary:

Volunteers with CACHE will be hosting a private wine and artwork fundraiser on Saturday, May 16, 2026, from 4:00 p.m. to 7:00 p.m. Ticket purchase allows attendees to gather in the front yards of four participating homes, where they may enjoy displayed artwork from local artists, along with appetizers and fine wine. The requested street closure will help ensure pedestrian safety and create a controlled, private event atmosphere.

Conditions of Approval:

Approval of the event is subject to the following conditions:

- 1) The City of Exeter will post temporary road closure signs 72 hours prior to the event and will handle the setup and removal of road closure barricades on the day of the event.
- 2) CACHE shall provide the appropriate insurance, naming the City of Exeter as an additional insured.

For action by:

City Council

Regular Session:

Consent Calendar

Regular Item

Public Hearing

Review:

City Administrator
(Initials Required)

J.R.

- 3) The distribution or sale of alcohol shall be limited to private property and must comply with all ABC licensing requirements.
- 4) CACHE shall be responsible for the removal of any trash left within the public right-of-way.

Fiscal Impact:

The total estimated permit fee associated with the event is \$103.00, as outlined below.

- Street Closure Permit: \$103.00

If approved, *the city will forgo this revenue.*

Prior City Council Actions:

This is an annual event and City Council most recently approved this event on April 22, 2025.

Attachments:

- Street Closure Request
- Fee Waiver Request
- Authorized Signature Page
- Street Closure Map

Recommended motion to be made by the City Council:

I move to approve a street closure of E Street between E Cedar Street and Clarence Avenue for a private fundraising event hosted by the Center for Art, Culture, and History – Exeter (CACHE), along with a fee waiver of \$103, subject to the conditions of approval.



City of Exeter Street Closure Application

350 W. Firebaugh – PO Box 237, Exeter, CA 93221
Ph. #559-592-3318 Fax # 559-592-3516

Date of Event: 5/16/26

Name of group requesting street closure: CACHE

Name of contact person: Robin Stearns Phone: [REDACTED]

Mailing address: [REDACTED] Email: [REDACTED]

Alternate Contact Person: _____ Phone: _____

Mailing Address: _____ Phone: _____

Type of event: Art + wine walk fundraiser

Time of closure: 4 until 7

Details of streets/parking lots/public right of way requesting to be closed: (provide map or additional pages if necessary)

Cedar - Clarence St. on S. E St.

RS I understand my \$103 application fee is nonrefundable however, if the event is rescheduled due to inclement weather or other unforeseen reasons, I will not be required to pay a second application fee.

RS I understand I am responsible for obtaining signatures from all locations that will be affected by the closure.

RS I understand all terms and conditions including the need for liability insurance will be required.

Applicant Signature: [REDACTED] Date 5/19/26

April 20, 2026

Dear Marie,

CACHE is having our 3rd annual Red Wine and Blue Wine/Art walk fundraiser on May 16, 2026. This year we are embracing the 250 anniversary of America and are going all out in a patriotic theme. We are asking that the City of Exeter waive the \$100 fee for the street closer. As you know we are a non profit and this event is to raise money for our facility. This would be of great help and very much appreciated.

Thank you,

Robyn Stearns
CACHE board

City of Exeter
Street Closure Authorization Form



CACHE is requesting a street closure to include S. E St. on
5/16/26 between the hours of 4 and 7 for Cedar-Clarenc

The locations listed below will be affected by this closure.

Address	Agree	Oppose	Business/Resident Name	Signature	Phone
200 S. Exeter	✓		Rabyn Stearns	[Redacted Signature]	[Redacted Phone]
463 S E St	✓		VICKI Riddle		
425 S E St	✓		DARBY RASMUSSE		
441 S E St	✓		Tracy Meris		
445 S E St	✓		John Cairns		
475 S E St	✓		ZIMM		
475 S E St	✓		Rosemary Helton		

City of Exeter

Legend

--- Art & Wine Walk Closure



65

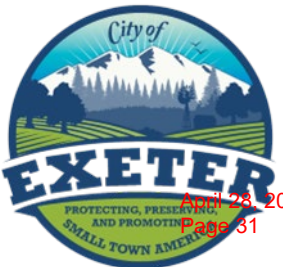
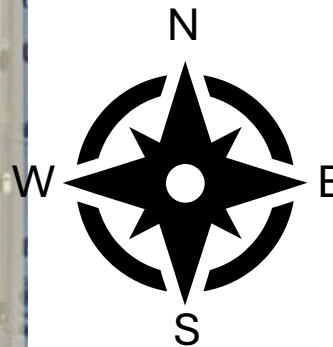



Agenda Item Staff Report

Agenda Item Number:

I.5.

Meeting Date:

April 28, 2026

Wording for Agenda:

Schedule a Special joint City Council Meeting with the Exeter Unified School District Board of Trustees on May 6, 2026.

Submitting Department:

Administration

Contact Name:

Jason Ridenour, City Administrator

For action by:

City Council

Regular Session:

Consent Calendar

Regular Item

Public Hearing

Review:

City Administrator
(Initials Required)

J.R.

Department Recommendation:

Staff recommend that City Council schedule a joint meeting with Exeter Unified School District Board of Trustees on Wednesday, May 6, 2026.

Background and Summary:

The City of Exeter and the Exeter Unified School District have a long history of working together for the betterment of the community. This is evident in the efforts to improve the safety for student and the community along State Route 65 and through a partnership of the use of facilities for youth sports programs.

At the City Council meeting on June 24, 2025, the City Council established their goals and objectives and affirmed them on August 12, 2025. A joint City Council and Exeter Unified School District Board of Trustees meeting was included on the established list of goals and objectives. The joint meeting is proposed to take place on Wednesday, May 6, 2026, at 5:00pm at the Exeter Unified School District Board Room.

Fiscal Impact:

There is no fiscal impact associated with this action.

Prior City Council Actions:

- June 24, 2025 – City Council established goals and objectives including a joint meeting with Exeter Unified School District Board of Trustees.

- August 12, 2025 - City Council affirmed goals and objectives including a joint meeting with Exeter Unified School District Board of Trustees.

Attachments:

None.

Recommended motion to be made by the City Council:

I move to schedule a special joint City Council meeting with the Exeter Unified School District Board of Trustees on May 6, 2026, at 5:00pm to take place at the Exeter Unified School District Board Room.



Agenda Item Staff Report

Agenda Item Number:

I.6.

Meeting Date:

April 28, 2026

Wording for Agenda:

Adoption of Resolution No. 2026-12, A Resolution of the City Council of the City of Exeter, Approving the Filing of a Notice of Exemption Pursuant to the California Environmental Quality Act (CEQA) for the Exeter Test Well Drilling and Sampling #2 Project.

Submitting Department:

Public Works

Contact Name:

Zachary Boudreaux, Director of Public Works

Department Recommendation:

Staff recommends that the City Council adopt Resolution No. 2026-12, approving the filing of a Notice of Exemption (NOE) pursuant to the California Environmental Quality Act (CEQA) for the Exeter Test Well Drilling and Sampling #2 Project, and authorizing the City Administrator and/or designee to execute and file the NOE with the Tulare County Clerk and the State Office of Planning and Research.

Summary:

The proposed Exeter Test Well Drilling and Sampling #2 Project is a subtask of the Tooleville Emergency Intertie Project and consists of drilling one test hole in front of the City's Public Works Yard to collect water quantity and quality data needed to design a new municipal production well. The test hole will be abandoned upon completion of sampling. The project qualifies as a Categorical Exemption from CEQA under Section 15306 (Information Collection). Staff has prepared the attached Notice of Exemption for filing with the Tulare County Clerk and the State Office of Planning and Research upon Council approval.

Background:

Exeter Test Well Drilling and Sampling #2 Project is part of the Tooleville Emergency Intertie Project, which will connect the disadvantaged community of Tooleville to the City of Exeter's municipal water system through a new well and associated infrastructure. Before the new

For action by:

City Council

Regular Session:

Consent Calendar

Regular Item

Public Hearing

Review:

City Administrator
(Initials Required)

J.R.

production well can be designed, subsurface water quantity and water quality data must be collected at the proposed site. The proposed test hole is located just south of the West Firebaugh Avenue and South G Street intersection, in front of the City of Exeter Public Works Yard (APN 135-109-031). After sampling and testing are completed, the test hole will be abandoned in accordance with applicable state and local well standards. No permanent structures will be constructed as part of this task.

The Exeter Test Well Drilling and Sampling #2 Project is exempt from the requirements of the California Environmental Quality Act (CEQA) pursuant to:

- Section 15306 – Information Collection. This categorical exemption applies to basic data collection, research, experimental management, and resource evaluation activities that do not result in a serious or major disturbance to an environmental resource. The proposed project is needed to collect water quantity and quality data required for the design of a new municipal production well associated with the Tooleville Emergency Intertie Project. Only one test hole would be drilled and ground disturbance would be minimal. No exceptions to the exemption under CEQA Guidelines Section 15300.2 were identified. Therefore, the Project is exempt under CEQA.

A Notice of Exemption (NOE) has been prepared and is included as an attachment to this report. Upon adoption of Resolution No. 2026-12, the NOE will be filed with the Tulare County Clerk and the State Office of Planning and Research.

Fiscal Impact:

All associated costs of this project are covered under the emergency intertie grant through the State of California Water Resources Control Board and are reimbursed to the City of Exeter on a regular basis. No direct permanent fiscal impact is implemented on the City.

Prior City Council Actions:

The City Council has previously approved actions related to the Tooleville Emergency Intertie Project, including project planning and funding necessary to advance regional water system improvements.

Attachments:

- Resolution No. 2026-12
- Notice of Exemption – Exeter Test Well Drilling and Sampling #2

Recommended motion to be made by the City Council:

I move to adopt Resolution No. 2026-12, A Resolution of the City Council of the City of Exeter, Approving the Filing of a Notice of Exemption Pursuant to the California Environmental Quality Act (CEQA) for the Exeter Test Well Drilling and Sampling #2 Project.

RESOLUTION NO. 2026-12

A RESOLUTION OF THE CITY COUNCIL OF THE CITY OF EXETER, CALIFORNIA, APPROVING THE FILING OF A NOTICE OF EXEMPTION PURSUANT TO THE CALIFORNIA ENVIRONMENTAL QUALITY ACT (CEQA) FOR THE EXETER TEST WELL DRILLING AND SAMPLING #2 PROJECT

WHEREAS, the City of Exeter (City) is implementing the Tooleville Emergency Intertie Project to connect the disadvantaged community of Tooleville to the City's municipal water system, which includes the construction of a new municipal production well; and

WHEREAS, as a subtask of the Tooleville Emergency Intertie Project, the City proposes to drill one test hole at the City of Exeter Public Works Yard, located just south of the West Firebaugh Avenue and South G Street intersection (Assessor's Parcel Number 135-109-031), to gather water quantity and water quality data needed to design the new production well (the "Project"); and

WHEREAS, the test hole will be properly abandoned upon completion of sampling and testing in accordance with applicable state and local well standards, and no permanent structures will be constructed as part of the Project; and

WHEREAS, all costs of the Project will be paid from the state grant funding previously awarded to the City for the Tooleville Emergency Intertie Project, with no impact to the City's General Fund; and

WHEREAS, the Project is exempt from the requirements of the California Environmental Quality Act (CEQA) pursuant to CEQA Guidelines Article 19, Section 15306 (Information Collection), as it consists of basic data collection and resource evaluation activities that will not result in a serious or major disturbance to an environmental resource, and no exceptions under CEQA Guidelines Section 15300.2 apply; and

WHEREAS, a Notice of Exemption has been prepared for the Project and is attached hereto and incorporated herein by reference, and City staff desires to file the Notice of Exemption with the Tulare County Clerk and the State Office of Planning and Research in accordance with Public Resources Code Sections 21108 and 21152.

NOW, THEREFORE, THE CITY COUNCIL OF THE CITY OF EXETER HEREBY FINDS, DETERMINES AND RESOLVES AS FOLLOWS:

Section 1. The foregoing recitals are true and correct and are hereby incorporated into this Resolution as though fully set forth herein.

Section 2. The City Council hereby finds and determines that the Exeter Test Well Drilling and Sampling #2 Project is exempt from the requirements of the California Environmental Quality Act (CEQA) pursuant to CEQA Guidelines Article 19, Section 15306 (Information Collection), as the Project consists of basic data collection, research,

and resource evaluation activities that will not result in a serious or major disturbance to an environmental resource, and no exceptions under CEQA Guidelines Section 15300.2 apply.

Section 3. The Notice of Exemption attached hereto is hereby approved, and the City Administrator and/or City Clerk, or their designee, is authorized and directed to execute and file the Notice of Exemption with the Tulare County Clerk and the State Office of Planning and Research, together with any required filing fees.

Section 4. Severability. The provisions of this Resolution are severable and if any provision, clause, sentence, word or part thereof is held illegal, invalid, unconstitutional, or inapplicable to any person or circumstances, such illegality, invalidity, unconstitutionality, or inapplicability shall not affect or impair any of the remaining provisions, clauses, sentences, sections, words or parts thereof of the Resolution or their applicability to other persons or circumstances.

Section 5. Effective Date. That the City Clerk shall certify to the adoption of this Resolution and that the same shall be in full force and effect.

PASSED AND ADOPTED by the City Council of the City of Exeter this 28th day of April, 2026 by the following vote:

AYES:

NOES:

ABSTAIN:

ABSENT:

Jacob Johnson, Mayor

ATTEST:

Francesca Quintana, City Clerk

Notice of Exemption**Appendix E**

To: Office of Planning and Research
P.O. Box 3044, Room 113
Sacramento, CA 95812-3044

County Clerk

County of: _____

From: (Public Agency): _____

(Address)

Project Title: _____

Project Applicant: _____

Project Location - Specific:

Project Location - City: _____ Project Location - County: _____

Description of Nature, Purpose and Beneficiaries of Project:

Name of Public Agency Approving Project: _____

Name of Person or Agency Carrying Out Project: _____

Exempt Status: **(check one):**

- Ministerial (Sec. 21080(b)(1); 15268);
- Declared Emergency (Sec. 21080(b)(3); 15269(a));
- Emergency Project (Sec. 21080(b)(4); 15269(b)(c));
- Categorical Exemption. State type and section number: _____
- Statutory Exemptions. State code number: _____

Reasons why project is exempt:

Lead Agency

Contact Person: _____ Area Code/Telephone/Extension: _____

If filed by applicant:

1. Attach certified document of exemption finding.
2. Has a Notice of Exemption been filed by the public agency approving the project? Yes No

Signature: _____ Date: _____ Title: _____

Signed by Lead Agency Signed by Applicant

Authority cited: Sections 21083 and 21110, Public Resources Code.
Reference: Sections 21108, 21152, and 21152.1, Public Resources Code.

Date Received for filing at OPR: _____



Agenda Item Staff Report

Agenda Item Number:

I.7.

Meeting Date:

April 28, 2026

Wording for Agenda:

Receive and File the City Treasurer's Report for December 2025.

Submitting Department:

Finance

Contact Name:

Rene Miller, Finance Manager

For action by:

City Council

Regular Session:

Consent Calendar

Regular Item

Public Hearing

Review:

City Administrator
(Initials Required)

J.R.

Department Recommendation:

Staff recommends that the City Council receive and file the City Treasurer's Report for December 2025.

Summary:

The attached City Treasurer's Report provides a summary of the City's banking activity, reconciles those balances to the City's general ledger, and identifies where City funds were invested as of December 31, 2025. The report reflects the City's use of the California Local Agency Investment Fund (LAIF), treasury notes, and other liquid investments held by U.S. Bank Trust. The report is prepared in accordance with the City's investment policy and applicable provisions of California Government Code Section 53600.

Background:

After several government entities had large negative investment results in the 1990's, the State of California developed new investment policies for Cities and other local agencies to follow. One requirement is investment reporting to the approving board. The Finance department presents the treasurer's report quarterly to the City Council. The City invests excess city funds in the Local Agency Investment Fund (LAIF), treasury notes and certificates of deposit with various maturity dates. The rates on the treasury notes and CDs vary from 1.62% to 4.40% whereas the LAIF Fund rate at December 31, 2025, was 4.2%.

Governmental Accounting required Cities record unrealized gains and losses in their general ledgers. Presently the unrealized portion of the gains and losses are only reflected in the

general fund. The treasurer's report does not reflect the unrealized gain or loss for the last quarter. A year-to-date unrealized gain or loss will be reflected on the next report that will be completed for March 31, 2026.

Fiscal Impact:

None associated with this action.

Prior City Council Actions:

City Council receives and files Treasurer's Reports quarterly.

Attachments:

- Treasurer's Report for December 31, 2025

Recommended motion to be made by the City Council:

I move to receive and file the City Treasurer's Report for December 31, 2025.

CITY OF EXETER TREASURER'S REPORT

PO BOX 237 - 137 N F STREET, EXETER 93221
Phone 592-3710 - Fax 592-3556

Quarter 2

		<u>10/31/2025</u>	<u>11/30/2025</u>	<u>12/31/2025</u>
CASH ON HAND				
Beginning Balance		\$ 1,170,490.20	\$ 1,334,419.42	\$ 2,025,034.89
Deposits				
	Beginning Deposits in Transit	\$ 47,774.57	\$ 27,010.03	\$ 7,806.08
	Bank Deposit (Cash/Checks)	\$ 424,775.22	\$ 699,215.20	\$ 379,541.07
	Payroll Return ACH	\$ -	\$ 1,738.99	\$ -
	LAIF to BOTS Transfer	\$ 1,000,000.00	\$ -	\$ -
	Direct Deposit (Paymentus, Ipay, ACH Receipts)	\$ 667,619.35	\$ 827,547.13	\$ 2,790,400.77
	Total deposits	\$ 2,140,169.14	\$ 1,555,511.35	\$ 3,177,747.92
Withdrawals				
	City Checks Processed	\$ 1,486,911.11	\$ 552,908.76	\$ 1,828,449.69
	Manual Disbursements	\$ 12,459.67	\$ 15,617.27	\$ 15,988.11
	CalPERS Retirement costs	\$ 61,282.29	\$ 60,484.06	\$ 61,879.67
	Payroll Taxes	\$ 34,007.81	\$ 37,694.11	\$ 52,003.86
	FSA Disbursements	\$ 757.10	\$ 759.39	\$ 355.49
	Chargebacks	\$ 1,077.73	\$ 4,830.23	\$ 1,143.44
	State DCSS	\$ 1,192.77	\$ 676.98	\$ 676.98
	Bank Fees	\$ 100.00	\$ 80.00	\$ -
	Water/Sewer Bond Payment	\$ 193,793.85	\$ -	\$ -
	Transfer to LAIF	\$ -	\$ -	\$ 2,000,000.00
	FP Mailing Postage	\$ -	\$ -	\$ 1,443.61
	USPS Postage	\$ 306.38	\$ 1,270.10	\$ 288.14
	BOTS ACH Positive Pay	\$ -	\$ -	\$ 85.40
	Total Withdrawals	\$ 1,976,239.92	\$ 864,895.88	\$ 4,167,644.98
Ending Bank Balance		\$ 1,334,419.42	\$ 2,025,034.89	\$ 1,035,137.83
	Undeposited Cash on Hand	\$ 15,556.68	\$ 8,205.78	\$ 2,437.32
	Paymentus Timing of Utility Payments	\$ 11,853.05	\$ -	\$ 11,454.57
	Total Outstanding Deposits	\$ 27,409.73	\$ 8,205.78	\$ 13,891.89
Outstanding Checks				
	General	\$ 411,476.81	\$ 1,656,684.34	\$ 210,390.75
	Payroll	\$ 2,201.24	\$ 2,605.04	\$ 2,706.15
	Total outstanding checks	\$ 413,678.05	\$ 1,659,289.38	\$ 213,096.90
Adjusted Bank Balance		\$ 948,151.10	\$ 373,951.29	\$ 835,932.82

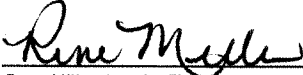
Prepared By: 
Rene Miller, Interim Finance Manager

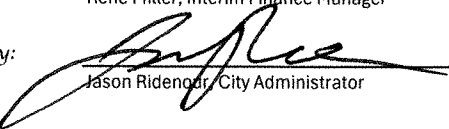
Approved By: 
Jason Ridenour, City Administrator

CITY OF EXETER INVESTMENT REPORT

PO BOX 237 - 137 N F STREET, EXETER 93221 Phone: 559-592-3710

For quarter ending

12/31/2025

Beginning Cash Balance		\$ 24,892,641.18
Disbursements	(433,028.19)	
Journal-Entries	(81,013.67)	
Manual-Disbursements	38,035.63	
Payroll	(208,871.52)	
Receipts	2,573,179.14	
Utilities	609,111.48	
Reconciled Ending Cash Balance		\$ 27,390,054.05

INVESTMENTS						
	Exeter PD Safekeeping				Total:	\$ 12,982.24
	Petty Cash				Total:	\$ 1,100.00
	Charles Scwab	Various	Demand		\$	0.23
					\$	14,082.47

MONEY MARKET FUNDS	TITLE	PURCHASE DATE	MATURITY DATE	RATE	PAR VALUE	
	Local Agency Investment Fund	Various	Demand	4.21200%	\$ 20,483,888.14	
	US Bank Trust Revenue Fund	Various	Demand	8.00511%	\$ 544,673.09	
	US Savings	Various	Demand	0.08997%	\$ 11.47	
					Total:	\$ 21,028,572.70

TREASURY OBLIGATIONS	TITLE	PURCHASE DATE	MATURITY DATE	RATE	PAR VALUE	PRINCIPAL COST
US Treasury	US Treasury Obligations Bond	Oct-21	11/30/2026	1.625%	\$ 500,000	\$ 513,457.03
	US Govt Agency Securities Bond	Mar-24	6/23/2026	4.375%	\$ 1,030,000	\$ 1,030,047.38
	Unrealized Gain/Loss					\$ 1,961.34
					Total:	\$ 1,530,000 \$ 1,545,465.75

CERTIFICATE OF DEPOSIT	TITLE	PURCHASE DATE	MATURITY DATE	RATE	PAR VALUE	PRINCIPAL COST	
CD	First Bank Richmond NA IN CD	Dec-23	1/29/2026	4.400%	\$ 244,000	\$ 244,000	
CD	Morgan Stanley Private BK NATL	Sep-24	3/11/2026	4.150%	\$ 245,000	\$ 245,000	
CD	Dundee Bank Omaha	Apr-22	4/8/2027	2.250%	\$ 247,000	\$ 247,000	
CD	Members Trust of SW FCU	Feb-24	2/28/2028	4.250%	\$ 249,000	\$ 249,000	
CD	Alabama Credit Union	Feb-24	2/28/2028	4.350%	\$ 249,000	\$ 249,000	
CD	BNY Mellon NA INSTL CTF DEP	Mar-25	3/8/2027	4.100%	\$ 244,000	\$ 244,000	
CD	American Express Natl BK BROK	Mar-25	3/6/2028	4.250%	\$ 244,000	\$ 244,000	
CD	Valley National Bank Wayne	Mar-25	3/6/2028	4.250%	\$ 244,000	\$ 244,000	
					4.92%	\$ 1,966,000	\$ 1,966,000

Total Investments **\$ 24,554,120.92**
Total City Funds **\$ 25,390,053.74**
Ratio of Invested Funds/Available Funds **97%**

I verify that this investment portfolio is in conformity with all State laws and the City's Investment Policy which is approved annually by the City Council.
 The Treasurer's cash management program provides sufficient liquidity to meet expenditure requirements for the next three months.

 Rene Miller, Interim Finance Manager



Agenda Item Staff Report

Agenda Item Number:

I.8.

Meeting Date:

April 28, 2026

Wording for Agenda:

Approval of a Request for the Exeter Kiwanis Club to Host a Special Event Celebrating 100 Years of the Exeter City Park Wading Pool and Dedication Wading Pool Improvements on June 7, 2026, and Approval of a Special Event Fee Waiver.

Submitting Department:

Public Works

Contact Name:

Marie Arroyo, Senior Administrative Assistant

Department Recommendation:

Staff recommends that the City Council approve the request for the Exeter Kiwanis Club to host a special event celebrating 100 years of the Exeter City Park wading pool, and approval of a Special Event Fee waiver ,subject to the conditions of approval outlined below.

Background & Summary:

The Exeter Kiwanis Club is requesting use of the City Park Wading Pool area on Sunday, June 7, 2026, from 8:00 a.m. to 3:00 p.m. to host a commemorative event celebrating the 100-year anniversary of the wading pool, as well as a fee waiver. The event will include supervised water play for children, with certified lifeguards on duty, and a formal dedication ceremony scheduled for 1:00 p.m. Additional time is requested to accommodate event setup, photography, and cleanup. This will be a free, alcohol-free community event open to the public.

The Exeter Kiwanis Club is part of a global volunteer organization dedicated to improving the lives of children. In 1926, the Club participated in the nationwide “Zero Hour Event,” unveiling the City of Exeter wading pool at City Park on June 7th at 4:00 p.m. Eastern Time. For many years, the pool served as a valued recreational amenity for local families. In recent years, the facility has remained non-operational.

In coordination with City staff, Exeter Kiwanis volunteers have worked to support efforts to reactivate and highlight this historic feature for this event. The June 7, 2026, event will

For action by:

City Council

Regular Session:

Consent Calendar

Regular Item

Public Hearing

Review:

City Administrator
(Initials Required)

J.R.

commemorate the original unveiling, occurring exactly 100 years later, aligning with the historic “Zero Hour Event” timing.

Conditions of Approval:

Approval of the event is subject to the following conditions:

- 1) The Exeter Kiwanis Club will provide a minimum of two lifeguards during the event and ensure all lifeguards on duty hold a valid lifeguard and CPR certification.
- 2) The Exeter Kiwanis Club will provide a Certification of Insurance, naming the City of Exeter an additional insured and be responsible for providing waivers of liability to participants.

Fiscal Impact:

There is minimal fiscal impact associated with this item. Any minor staff time associated with coordination and support of the event is anticipated to be absorbed within existing departmental budgets.

The total estimated permit fee associated with the event is \$171.00, as outlined below.

- Special Event Permit: \$171.00

If approved, *the city will forgo this revenue.*

Prior City Council Actions:

None associated with this action.

Attachments:

- Application

Recommended motion to be made by the City Council:

I move to approve the request for the Exeter Kiwanis Club to host a special event on June 7, 2026, celebrating 100 years of the Exeter City Park wading pool, subject to the conditions of approval.

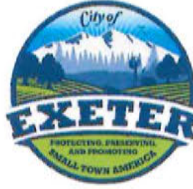

**CITY OF EXETER
FACILITY USE APPLICATION**

Application Date: 4/20/26 **Facility/Park Requested:** City Park Wading Pool
Date(s) Needed: June 7, 2026 **Equipment Needed:** _____
Set-up Time: 8:00am **Departure Time:** 3:00pm
Event Start Time: 9:00 **Event End Time:** 1:00pm
Name of Organization: Exeter Kiwanis Club
Type of Event: Kiwanis Wading Pool Recognition
Address: City of Exeter , City Park

FACILITY USE POLICY:

The following rules and regulations will be strictly adhered to and enforced. Any infraction thereof shall be grounds for the immediate termination of the activity.

1. All facility users must comply with Tulare County Health Department regulations and any applicable City of Exeter requirements.
2. Users may utilize picnic benches, tables, or arbors owned by the City. Additional equipment and supplies must be provided by the applicant.
3. Nails, tacks, pins, or staples are not permitted on facility structures. Only masking tape or other approved materials may be used for decorations. All decorations must be removed at the conclusion of the event.
4. Driving or parking on grass areas is strictly prohibited unless authorized by the City.
5. After the event, users must collect all trash and place it in provided receptacles. The facility must be left clean and in its original condition.
6. Alcohol consumption is permitted only with prior City approval and in compliance with Chapter 5.08 of the Exeter Municipal Code. A separate Alcoholic Beverage Permit is required.

Insurance and Waivers:

- General Liability Insurance:
 - Commercial general liability insurance with coverage at least as broad as Insurance Services Office (ISO) form CG 00 01, in an amount not less than \$2,000,000 per occurrence, general aggregate, and \$2,000,000 products and completed operations. The policy shall include a per project or per location general aggregate endorsement. If a per project/location endorsement is not available, the limit for the general aggregate shall be doubled.
 - The policy shall allow and be endorsed as primary and not seek contribution from the City's coverage.
 - The policy(s) shall provide and be endorsed to include, the City, its officers, officials, employees, agents, and volunteers as additional insureds on ISO form CG 20 10 (or equivalent) for ongoing operations, and, for construction or service agreements, ISO form CG 20 37 (or equivalent) for completed operations.
 - Any failure to comply with reporting provisions of the policies by Applicant shall not affect coverage provided to the City.
 - Coverage shall state that Vendor's insurance shall apply separately to each insured against whom claim is made or suit is brought, except with respect to the limits of the insurer's liability.
 - Coverage shall allow and be endorsed to include a waiver of subrogation in favor of the City and its officers, officials, employees, and agents.
 - When alcohol is served or sold, liquor liability coverage is required.

- Workers' Compensation and Employers' Liability - Statutory
 - Applicant shall, at its sole cost and expense, maintain Statutory Workers' Compensation Insurance and Employer's Liability Insurance for all persons employed directly or indirectly by Applicant. The Statutory Workers' Compensation Insurance and Employer's Liability Insurance shall be provided with limits of not less than \$1,000,000 each accident, \$1,000,000 by disease-policy limit, and \$1,000,000 by disease-each employee. No proprietor, partner, executive officer, or member shall be excluded. In the alternative, Applicant may rely on a self-insurance program to meet those requirements, but only if the program of self-insurance complies fully with the provisions of the California Labor Code.

Determination of whether a self-insurance program meets the standards of the California Labor Code shall be solely in the discretion of City.

- The insurer, if insurance is provided, or Applicant, if a program of self-insurance is provided, shall allow, and be endorsed to waive all rights of subrogation against City and its officers, officials, employees, agents, and volunteers.
- The requirement to maintain Statutory Worker's Compensation and Employer's Liability Insurance may be waived by the City upon written verification that Vendor does not have any employees.

- **Indemnity/Hold Harmless Agreement:**

- The applicant agrees to indemnify, defend, and hold harmless the City of Exeter, its officers, employees, agents, and volunteers from any and all claims, damages, or liabilities arising out of facility use, except for those caused by the sole negligence or willful misconduct of the City.

I have read and agree to the above Facility Use Policy and requirements.

Applicant/Organization Name: Exeter Kiwanis

Signature: [Redacted]

Date: 4/20/26

Phone Number: [Redacted]

Email: [Redacted]

This Section for City Staff Use Only:

Rental Fee: _____	Date Paid: _____
Cash or Check: _____	Received by: _____
Certificate of Insurance Received: _____	Approved by: _____



Agenda Item Staff Report

Agenda Item Number:

I.9.

Meeting Date:

April 28, 2026

Wording for Agenda:

Approval of a Special Event and Facility Use Request by the Exeter Golf Course for a Golf Cart Parade on July 4, 2026, and Approval of a Special Event Fee Waiver.

Submitting Department:

Public Works

Contact Name:

Marie Arroyo, Senior Administrative Assistant

Department Recommendation:

Staff recommends that the City Council approve the special event and facility use request from the Exeter Golf Course to host a Golf Cart Parade from City Hall to City Park on July 4, 2026, and approval of a Special Event Fee waiver, subject to the conditions of approval.

Background & Summary:

Over the past several months, volunteers from the E250 Committee have collaborated with the Community organizations to organize a community celebration in honor of America's 250th birthday.

The Exeter Golf Course submitted a request to host a decorated golf cart parade as well as a fee waiver. The parade will stage in the City overflow parking lot on North F Street, travel southbound on North F Street to Pine Street, then head east to South D Street, south on South D Street to West Chestnut Street, west on West Chestnut Street to South F Street and conclude at the staging area. The parade participants will be escorted by the Exeter Police Department, with a rolling street closure implemented to ensure public safety. This event is free and open to the public and is anticipated to draw significant community participation.

Conditions of Approval:

Approval of the event is subject to the following conditions:

1. **Insurance:** A certificate of Insurance will be required naming the city as an additional insured.

For action by:

City Council

Regular Session:

Consent Calendar

Regular Item

Public Hearing

Review:

City Administrator
(Initials Required)

J.R.

2. **Alcohol Regulations:** This is an alcohol-free event
3. **Trash:** The E250 Committee is responsible for the coordination of post event trash removal.

Fiscal Impact:

There is minimal fiscal impact associated with this item. Staff time for coordination and support will be absorbed within existing departmental budgets.

The total estimated permit fee associated with the event is \$171.00, as outlined below.

- Special Event Permit: \$171.00

If approved, *the city will forgo this revenue.*

Prior City Council Actions:

On April 18, 2026, the City Council approved related event components.

Attachments:

- Application
- Map of Parade Route

Recommended motion to be made by the City Council:

I move to approve the special event and facility use request from the Exeter Chamber of Commerce for a Golf Cart Parade on July 4, 2026, along with a fee waiver of \$171, subject to the conditions of approval.



**CITY OF EXETER
FACILITY USE APPLICATION**

Application Date: 4.3.24 Facility/Park Requested: Rolling Parade closure

Date(s) Needed: 7.4.24 Equipment Needed: _____

Set-up Time: _____ Departure Time: _____

Event Start Time: _____ Event End Time: _____

Name of Organization: The Exeter Golf Course

Type of Event: Rolling Golf Cart Parade

Address: 137 N. F St

FACILITY USE POLICY:



The following rules and regulations will be strictly adhered to and enforced. Any infraction thereof shall be grounds for the immediate termination of the activity.

1. All facility users must comply with Tulare County Health Department regulations and any applicable City of Exeter requirements.
2. Users may utilize picnic benches, tables, or arbors owned by the City. Additional equipment and supplies must be provided by the applicant.
3. Nails, tacks, pins, or staples are not permitted on facility structures. Only masking tape or other approved materials may be used for decorations. All decorations must be removed at the conclusion of the event.
4. Driving or parking on grass areas is strictly prohibited unless authorized by the City.
5. After the event, users must collect all trash and place it in provided receptacles. The facility must be left clean and in its original condition.
6. Alcohol consumption is permitted only with prior City approval and in compliance with Chapter 5.08 of the Exeter Municipal Code. A separate Alcoholic Beverage Permit is required.

Determination of whether a self-insurance program meets the standards of the California Labor Code shall be solely in the discretion of City.

- The insurer, if insurance is provided, or Applicant, if a program of self-insurance is provided, shall allow, and be endorsed to waive all rights of subrogation against City and its officers, officials, employees, agents, and volunteers.
- The requirement to maintain Statutory Worker's Compensation and Employer's Liability Insurance may be waived by the City upon written verification that Vendor does not have any employees.
- **Indemnity/Hold Harmless Agreement:**
 - The applicant agrees to indemnify, defend, and hold harmless the City of Exeter, its officers, employees, agents, and volunteers from any and all claims, damages, or liabilities arising out of facility use, except for those caused by the sole negligence or willful misconduct of the City...

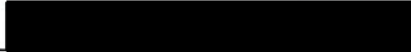
I have read and agree to the above Facility Use Policy and requirements.

Applicant/Organization Name: The Exeter Golf Course
Signature: 
Date: 4-3-24
Phone Number: 
Email: 

This Section for City Staff Use Only:

Rental Fee: _____	Date Paid: _____
Cash or Check: _____	Received by: _____
Certificate of Insurance Received: _____	Approved by: _____

City of Exeter

Legend

— Golf Cart Parade Route





Agenda Item Staff Report

Agenda Item Number: I.10.

Meeting Date:

April 28, 2026

Wording for Agenda:

Approval of a Special Event and Facility Use for the E250 Community Celebration Festivities at City Park on July 4, 2026, and Approval of a Special Event Fee Waiver.

Submitting Department:

Public Works

Contact Name:

Marie Arroyo, Senior Administrative Assistant

Department Recommendation:

Staff recommends that the City Council approve the Special Event and Facility Use for the E250 Community Celebration festivities at City Park on July 4, 2026, , and approval of a Special Event Fee waiver, subject to the conditions outlined below.

Background & Summary:

Over the past several months, volunteers from the E250 Committee have collaborated with community organizations to organize a community celebration in honor of America’s 250th birthday. The Exeter Kiwanis Club has submitted a request to hold a Fourth of July Community Event as well as a fee waiver.

The event will take place at City Park and is currently scheduled to begin at 9:00am. The Community event will include use of the wading pool, where the Exeter Kiwanis Club will provide certified lifeguards to supervise children during water play. In addition, the Exeter Chamber of Commerce will coordinate family-friendly games and activities designed to encourage community participation and create a welcoming environment for residents and visitors as part of the event.

This event is free and open to the public

Conditions of Approval:

Approval of the event is subject to the following conditions:

For action by:

City Council

Regular Session:

Consent Calendar

Regular Item

Public Hearing

Review:

City Administrator
(Initials Required)

J.R.

1. **Insurance:** A certificate of Insurance will be required naming the city as an additional insured.
2. **Alcohol Regulations:** This is an alcohol-free event
3. **Trash:** Applicant is responsible for the coordination of post event trash removal.

Fiscal Impact:

There is minimal fiscal impact associated with this item. Staff time for coordination and support will be absorbed within existing departmental budgets.

The total estimated permit fee associated with the event is \$171.00, as outlined below.

- Special Event Permit: \$171.00

If approved, *the city will forgo this revenue.*

Prior City Council Actions:

On April 18, 2026, City Council approved related event components, including the Exeter Kiwanis Club pancake breakfast.

Attachments:

- Application

Recommended motion to be made by the City Council:

I move to approve the Special Event and Facility Use for the E250 Community Celebration festivities at City Park on July 4, 2026, along with a fee waiver of \$171, subject to the conditions of approval.

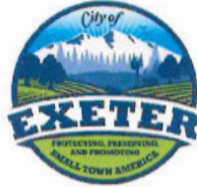

**CITY OF EXETER
FACILITY USE APPLICATION**

Application Date: 7/4/26 Facility/Park Requested: City Park Wading Pool
Date(s) Needed: July 4, 2026 Equipment Needed: _____
Set-up Time: 8:00am Departure Time: 4:00pm
Event Start Time: 9:00 Event End Time: 3:00pm
Name of Organization: Exeter Kiwanis Club
Type of Event: E250 Splash
Address: City of Exeter , City Park

FACILITY USE POLICY:

The following rules and regulations will be strictly adhered to and enforced. Any infraction thereof shall be grounds for the immediate termination of the activity.

1. All facility users must comply with Tulare County Health Department regulations and any applicable City of Exeter requirements.
2. Users may utilize picnic benches, tables, or arbors owned by the City. Additional equipment and supplies must be provided by the applicant.
3. Nails, tacks, pins, or staples are not permitted on facility structures. Only masking tape or other approved materials may be used for decorations. All decorations must be removed at the conclusion of the event.
4. Driving or parking on grass areas is strictly prohibited unless authorized by the City.
5. After the event, users must collect all trash and place it in provided receptacles. The facility must be left clean and in its original condition.
6. Alcohol consumption is permitted only with prior City approval and in compliance with Chapter 5.08 of the Exeter Municipal Code. A separate Alcoholic Beverage Permit is required.

Insurance and Waivers:

- General Liability Insurance:
 - Commercial general liability insurance with coverage at least as broad as Insurance Services Office (ISO) form CG 00 01, in an amount not less than \$2,000,000 per occurrence, general aggregate, and \$2,000,000 products and completed operations. The policy shall include a per project or per location general aggregate endorsement. If a per project/location endorsement is not available, the limit for the general aggregate shall be doubled.
 - The policy shall allow and be endorsed as primary and not seek contribution from the City's coverage.
 - The policy(s) shall provide and be endorsed to include, the City, its officers, officials, employees, agents, and volunteers as additional insureds on ISO form CG 20 10 (or equivalent) for ongoing operations, and, for construction or service agreements, ISO form CG 20 37 (or equivalent) for completed operations.
 - Any failure to comply with reporting provisions of the policies by Applicant shall not affect coverage provided to the City.
 - Coverage shall state that Vendor's insurance shall apply separately to each insured against whom claim is made or suit is brought, except with respect to the limits of the insurer's liability.
 - Coverage shall allow and be endorsed to include a waiver of subrogation in favor of the City and its officers, officials, employees, and agents.
 - When alcohol is served or sold, liquor liability coverage is required.

- Workers' Compensation and Employers' Liability - Statutory
 - Applicant shall, at its sole cost and expense, maintain Statutory Workers' Compensation Insurance and Employer's Liability Insurance for all persons employed directly or indirectly by Applicant. The Statutory Workers' Compensation Insurance and Employer's Liability Insurance shall be provided with limits of not less than \$1,000,000 each accident, \$1,000,000 by disease-policy limit, and \$1,000,000 by disease-each employee. No proprietor, partner, executive officer, or member shall be excluded. In the alternative, Applicant may rely on a self-insurance program to meet those requirements, but only if the program of self-insurance complies fully with the provisions of the California Labor Code.

Determination of whether a self-insurance program meets the standards of the California Labor Code shall be solely in the discretion of City.

- The insurer, if insurance is provided, or Applicant, if a program of self-insurance is provided, shall allow, and be endorsed to waive all rights of subrogation against City and its officers, officials, employees, agents, and volunteers.
- The requirement to maintain Statutory Worker's Compensation and Employer's Liability Insurance may be waived by the City upon written verification that Vendor does not have any employees.

- **Indemnity/Hold Harmless Agreement:**

- The applicant agrees to indemnify, defend, and hold harmless the City of Exeter, its officers, employees, agents, and volunteers from any and all claims, damages, or liabilities arising out of facility use, except for those caused by the sole negligence or willful misconduct of the City.

I have read and agree to the above Facility Use Policy and requirements.

Applicant/Organization Name: Exeter Kiwanis

Signature: [REDACTED]

Date: 4/20/26

Phone Number [REDACTED]

Email: [REDACTED]

This Section for City Staff Use Only:

Rental Fee: _____	Date Paid: _____
Cash or Check: _____	Received by: _____
Certificate of Insurance Received: _____	Approved by: _____



Agenda Item Staff Report

Agenda Item Number:

I.11.

Meeting Date:

April 28, 2026

Wording for Agenda:

Approval of the Selection of American Emergency Products (AEP) for Police Vehicle Outfitting Services and Authorize the City Administrator or their Designee to Execute all Necessary Documents.

Submitting Department:

Police

Contact Name:

Chief Rob Schimpf, Chief of Police

Department Recommendation:

Staff recommends that the City Council approve the selection of American Emergency Products (AEP) for police vehicle outfitting based on best value, reliability, and ability to meet operational timelines.

Summary:

Police vehicle outfitting is a specialized service requiring technical expertise and standardized installation to ensure officer safety and operational effectiveness. Staff evaluated multiple vendors based on cost, completeness, quality, and ability to deliver within required timelines. American Emergency Products (AEP) is recommended as the best overall value due to its proven performance, complete build to department specifications, and timely delivery capabilities.

Background:

Police vehicle outfitting involves the installation of emergency lighting, communications equipment, prisoner transport components, and other safety-critical systems. These installations must meet law enforcement operational standards and function reliably under emergency conditions.

For action by:

City Council

Regular Session:

Consent Calendar

Regular Item

Public Hearing

Review:

City Administrator
(Initials Required)

J.R.

Standardization across the fleet is essential to reduce training variability, improve operational efficiency, and ensure officer safety. Inconsistent or incomplete installations can lead to equipment failures, increased maintenance costs, and operational inefficiencies over time.

Staff solicited and reviewed proposals from Tulare County Information Technology (TCIT), Dana Safety Supply, and American Emergency Products (AEP). While TCIT provided the lowest initial cost, their proposal reflected a more minimalistic build that lacked the level of equipment and standardization included in other proposals. This approach may result in additional costs in the future if equipment needs to be added or modified after initial installation.

Additionally, TCIT advised that they are currently unable to begin outfitting vehicles due to shortages in on-hand inventory and may not be able to procure necessary equipment until the next fiscal year. This delay would prevent timely deployment of vehicles into service and impact operational readiness.

In contrast, American Emergency Products (AEP) demonstrated a higher level of standardization in their builds, supported by clear documentation and consistent installation practices at the next lowest cost. AEP also advised that they are able to complete outfitting within required timelines without anticipated delays.

These factors—including long-term cost considerations, standardization, and ability to deliver within necessary timeframes—support staff’s recommendation.

Fiscal Impact:

The total cost of outfitting will vary depending on vendor selection:

- American Emergency Products (AEP): \$26,899.10
- Dana Safety Supply: \$28,404.41
- Tulare County IT (TCIT): Approximately \$19,012.80 (minimalistic build)

Funding for this project is included in the department’s approved vehicle outfitting budget. While TCIT presents the lowest upfront cost, additional equipment, delays, and lack of standardization reduce overall value. AEP provides the best balance of cost, quality, and long-term reliability.

Prior City Council Actions:

None associated with this action.

Attachments:

- Quote Received from AEP
- Quote Received from Dana Safety Supply
- Quote Received from Tulare County IT (TCIT)

Recommended motion to be made by the City Council:

I move to approve the selection of American Emergency Products (AEP) for police vehicle outfitting and authorize the City Administrator or their designee to execute all necessary documents.



2025 Ford Police Interceptor Utility

April 28, 2026 Regular Meeting of the Exeter City Council
Page 61



AEP

A Soncell NA Company



Quotation

Date Apr 7, 2026	Page 1
Order Number QTE0043964	

AEP - California, LLC

3437 Landco Dr. Suite A
 Bakersfield, CA 93308
 Remit to: 10729 Wheatlands Ave. Suite C
 Santee, CA 92071

Sold To:

Exeter Police Department
 100 North C Street
 Exeter, CA 93221

Ship To:

Exeter Police Department
 100 North C Street
 Exeter, CA, 93221

Reference	PO Number	Customer No.	Salesperson	Order Date	Ship Via	Terms
2025 Patrol PIU x1 RevB (2026 Buil		EXE11001	AS	Apr 7, 2026	FEDEX	NET30

Year	Make	Model	Color	State Contract #
2025	Ford	PIU, EcoBoost	B/W	NA

Qty. Ord.	Item / Vendor Part Number	Description	Unit Price	Tax	Extended Price
		Contact 1: Lt. Rob Moore, 559-804-1696 rmoore@exeterpd.com Vehicle Availability: @ Exeter PD as of 3/20/26 VIN(s): 1: SGA02665 ***Lightbar / Siren Package***			
1.00	LBAR04916 / EMPLB01KPE-4Q0	mPower 55" Lightbar, R/B/W Front, R/B/A Rear, No Hook List \$6,290.00 less 55% / QSF123264	2,830.5000	Y	2,830.50
1.00	VACC03314 / PNFLBF44	Lightbar Hook Kit, 2020+ PIU	21.0000	Y	21.00
1.00	SIRE00687 / ENGSA5201	bluePRINT® 500 Series Siren 200W Remote Amp w/link	768.1500	Y	768.15
1.00	VACC03641 / ENGCP18003	Push Button Control Panel w/ Microphone	214.0000	Y	214.00
1.00	VACC03642 / ENGLNVH018	Vehicle Harness Blue Link F150 24/25/PIU	210.0000	Y	210.00

Quotation continued on next page ...



Quotation

Date Apr 7, 2026	Page 2
Order Number QTE0043964	

AEP - California, LLC

3437 Landco Dr. Suite A
 Bakersfield, CA 93308
 Remit to: 10729 Wheatlands Ave. Suite C
 Santee, CA 92071

Sold To:

Exeter Police Department
 100 North C Street
 Exeter, CA 93221

Ship To:

Exeter Police Department
 100 North C Street
 Exeter, CA, 93221

Reference	PO Number	Customer No.	Salesperson	Order Date	Ship Via	Terms
2025 Patrol PIU x1 RevB (2026 Buil		EXE11001	AS	Apr 7, 2026	FEDEX	NET30

Year	Make	Model	Color	State Contract #
2025	Ford	PIU, EcoBoost	B/W	NA

Qty. Ord.	Item / Vendor Part Number	Description	Unit Price	Tax	Extended Price
2.00	SPEA00253 / ETSS100J5	100 Watt Composite Siren Speaker w/ Univ Bkt, 5-YR Warranty	250.0000	Y	500.00
1.00	SIRE00566 / ENGSYMD01	bluePRINT SYNC Module with Antenna	278.5000	Y	278.50
		Push Bumper with Front Lighting			
1.00	BUMP00905 / BK1526ITU20	PB450-LR4 Push Bumper, SoundOff mPower x4, 2020+ Utility	544.7200	Y	544.72
2.00	LEDS04175 / EMPSCG2STS4D	3-Wire mPower Fascia LED, Stud Mount, 12-LED, Red/White	136.0000	Y	272.00
2.00	LEDS03901 / EMPSCG2STS4E	3-Wire mPower Fascia LED, Stud Mount, 12-LED, Blue/White	136.0000	Y	272.00
1.00	PATC00288 / FT-UNV-SOB5-BUM-02	Bumper Harness, bluePRINT 500 w/3-Wire x4, Universal	148.0000	Y	148.00
1.00	PATC00289 / FT-UNV-SOB5-SPK-01	Speaker Harness, SoundOff, Universal	38.4000	Y	38.40
		Headlight Housing LEDs			
1.00	LEDS03676 / ELUC3H010D	Universal Under Cover LED Insert, 5-Wire, Red/White	92.0000	Y	92.00
1.00	LEDS03657 / ELUC3H010E	Universal Under Cover LED Insert, 5-Wire, Blue/White	92.0000	Y	92.00

Quotation continued on next page ...				
---	--	--	--	--



Quotation

Date Apr 7, 2026	Page 3
Order Number QTE0043964	

AEP - California, LLC

3437 Landco Dr. Suite A
 Bakersfield, CA 93308
 Remit to: 10729 Wheatlands Ave. Suite C
 Santee, CA 92071

Sold To:

Exeter Police Department
 100 North C Street
 Exeter, CA 93221

Ship To:

Exeter Police Department
 100 North C Street
 Exeter, CA, 93221

Reference	PO Number	Customer No.	Salesperson	Order Date	Ship Via	Terms
2025 Patrol PIU x1 RevB (2026 Buil		EXE11001	AS	Apr 7, 2026	FEDEX	NET30

Year	Make	Model	Color	State Contract #
2025	Ford	PIU, EcoBoost	B/W	NA

Qty. Ord.	Item / Vendor Part Number	Description	Unit Price	Tax	Extended Price
2.00	LEDS02981 / PLUCTCL1	Twist-In UC LED Collar Kit ***Under Mirror LEDs***	4.0000	Y	8.00
1.00	LEDS04175 / EMPSCG2STS4D	3-Wire mPower Fascia LED, Stud Mount, 12-LED, Red/White	136.0000	Y	136.00
1.00	LEDS03901 / EMPSCG2STS4E	3-Wire mPower Fascia LED, Stud Mount, 12-LED, Blue/White	136.0000	Y	136.00
1.00	BKRT00359 / PMP2BKUMB8-D	Under Mirror Bracket, mPower/Intersector, 25+ Utility, DRV	28.5000	Y	28.50
1.00	BKRT00360 / PMP2BKUMB8-P	Under Mirror Bracket, mPower/Intersector, 25+ Utility, PAS	28.5000	Y	28.50
2.00	VACC02904 / FT-UNV-SOB5-3WR-02	bluePRINT 500 w/3-Wire LED Extension Single (Mirror), Univer ***Rear 1/4 Window LEDs***	30.4000	Y	60.80
1.00	LEDS04175 / EMPSCG2STS4D	3-Wire mPower Fascia LED, Stud Mount, 12-LED, Red/White	136.0000	Y	136.00
1.00	LEDS03901 / EMPSCG2STS4E	3-Wire mPower Fascia LED, Stud Mount, 12-LED, Blue/White	136.0000	Y	136.00

Quotation continued on next page ...				



Quotation

Date Apr 7, 2026	Page 4
Order Number QTE0043964	

AEP - California, LLC

3437 Landco Dr. Suite A
 Bakersfield, CA 93308
 Remit to: 10729 Wheatlands Ave. Suite C
 Santee, CA 92071

Sold To:

Exeter Police Department
 100 North C Street
 Exeter, CA 93221

Ship To:

Exeter Police Department
 100 North C Street
 Exeter, CA, 93221

Reference	PO Number	Customer No.	Salesperson	Order Date	Ship Via	Terms
2025 Patrol PIU x1 RevB (2026 Buil		EXE11001	AS	Apr 7, 2026	FEDEX	NET30

Year	Make	Model	Color	State Contract #
2025	Ford	PIU, EcoBoost	B/W	NA

Qty. Ord.	Item / Vendor Part Number	Description	Unit Price	Tax	Extended Price
2.00	LEDS03567 / PMP2WSSSB	4" mPower 25-90 degree Glass Mount/Shroud, Black	15.5000	Y	31.00
2.00	PATC00311 / FT-UNV-SOB5-3WR-03	bluePRINT 500 w/3-Wire LED Extension, 24", Universal	39.2000	Y	78.40
		Rear License Plate and Gate Open LEDs			
2.00	LEDS04369 / EMPSCG2QMS5RBW	3-Wire mPower 4" Fascia LED, QM, 18-LED, Red/Blue/White (Rear License Plate)	151.0000	Y	302.00
2.00	LEDS04370 / EMPSCG1SLS3J	3-Wire mPower 3" Fascia LED, SM, 8-LED, Red/Blue (Under Trim / Gate Open)	122.5000	Y	245.00
1.00	PATC00292 / FT-F01-SOB5-LFT-01	Liftgate Harness, bluePRINT 500 w/3-Wire, 20+ Utility	128.0000	Y	128.00
		Taillight LEDs / Taillight Flash			
2.00	LEDS03674 / ELUC3H010B	Universal Under Cover LED Insert, 5-Wire, Blue	92.0000	Y	184.00
2.00	LEDS02981 / PLUCTCL1	Twist-In UC LED Collar Kit	4.0000	Y	8.00
1.00	PATC00349 / FT-F06-SOB5-OEM-01	2025 PIU Taillight Flash Diode Pack	212.0000	Y	212.00
		Under Spoiler LEDs			

Quotation continued on next page ...



Quotation

Date Apr 7, 2026	Page 5
Order Number QTE0043964	

AEP - California, LLC

3437 Landco Dr. Suite A
 Bakersfield, CA 93308
 Remit to: 10729 Wheatlands Ave. Suite C
 Santee, CA 92071

Sold To:

Exeter Police Department
 100 North C Street
 Exeter, CA 93221

Ship To:

Exeter Police Department
 100 North C Street
 Exeter, CA, 93221

Reference	PO Number	Customer No.	Salesperson	Order Date	Ship Via	Terms
2025 Patrol PIU x1 RevB (2026 Buil		EXE11001	AS	Apr 7, 2026	FEDEX	NET30

Year	Make	Model	Color	State Contract #
2025	Ford	PIU, EcoBoost	B/W	NA

Qty. Ord.	Item / Vendor Part Number	Description	Unit Price	Tax	Extended Price
2.00	LEDS03996 / EMPSCG2STS5RBW	3-Wire mPower Fascia LED, Stud Mount, 18-LED, Red/Blue/White	151.0000	Y	302.00
1.00	BKRT00074 / PMP2RS101	Under Spoiler mPower Bracket, 1-Module, 2020 Utility	87.0000	Y	87.00
1.00	PATC00294 / FT-F01-SOB5-SPO-02	2-Mod Spoiler Harness, bluePRINT 500 w/3-Wire, 20+ Utility	104.0000	Y	104.00
		Spot Lights			
		Vehicle Equipped with OEM Spotlight Prep***			
1.00	SPOT00388 / 218016-0002	Unity 6" Spot Lamp w/ Unity LED, Driver Post 2020 Utility	395.0000	Y	395.00
1.00	SPOT00397 / 265	Spotlight Install Kit, 2020+ PIU Left Side	77.0000	Y	77.00
1.00	SPOT00390 / 218017-0002	Unity 6" Spot Lamp w/ Unity LED, Pass. Post 2020 Utility	395.0000	Y	395.00
1.00	SPOT00411 / 265-RH	Spotlight Install Kit, 2020+ PIU Right Side	77.0000	Y	77.00
		FasTech Harness/ Electrical System			
1.00	PATC00347 / FT-F06-SOB5-PRI-01	Primary Harness, bluePRINT 500 w/3-Wire, 2025 Utility	2,500.0000	Y	2,500.00

Quotation continued on next page ...				
---	--	--	--	--



Quotation

Date Apr 7, 2026	Page 6
Order Number QTE0043964	

AEP - California, LLC

3437 Landco Dr. Suite A
 Bakersfield, CA 93308
 Remit to: 10729 Wheatlands Ave. Suite C
 Santee, CA 92071

Sold To:

Exeter Police Department
 100 North C Street
 Exeter, CA 93221

Ship To:

Exeter Police Department
 100 North C Street
 Exeter, CA, 93221

Reference	PO Number	Customer No.	Salesperson	Order Date	Ship Via	Terms
2025 Patrol PIU x1 RevB (2026 Buil		EXE11001	AS	Apr 7, 2026	FEDEX	NET30

Year	Make	Model	Color	State Contract #
2025	Ford	PIU, EcoBoost	B/W	NA

Qty. Ord.	Item / Vendor Part Number	Description	Unit Price	Tax	Extended Price
1.00	PATC00291 / FT-F01-SOB5-UND-03	Underhood Harness, bluePRINT 500 w/3-Wire, 20+ Utility	396.0000	Y	396.00
1.00	PATC00350 / LIN-GUARD	LIN Guard Module Only	284.0000	Y	284.00
1.00	BKRT00092 / PIU20-EQUIP-001	Electronics Mounting Plate SOS, DRV 1/4 Panel, 20+ Utility	117.6000	Y	117.60
1.00	VACC02945 / B00FSYBKPM	Panel Mount USB-B Extension Cable, Panle Mount, 3'	18.0000	Y	18.00
1.00	VACC02241 / B07PPLK8L4	RJ45 Splitter, 1-Male to 3-Female, Use for BP SYNC/LINK/CP	24.0000	Y	24.00
1.00	VACC02325 / 491-SC36MP	Compact Foot Switch w/ Mounting Plate	128.0000	Y	128.00
		Center Equipment Console			
1.00	CONS01598 / 7170-0735-00	2020+ Ford Utility Short Console, w/ Cup Holder, 10"/4.5"	501.9000	Y	501.90
1.00	FACE00546 / 7160-0321	Console Faceplate Motorola APX-6500 -05 Remote, 3" PL 2013-05-15	0.0000	N	0.00
1.00	FACE00866 / 20033	Console Faceplate, SoundOff 500 Remote Siren, 3.5"	0.0000	N	0.00
1.00	FACE00735 / 15083	Six Rocker Switch Faceplate (Knockout), 2"	0.0000	N	0.00

Quotation continued on next page ...



Quotation

Date Apr 7, 2026	Page 7
Order Number QTE0043964	

AEP - California, LLC

3437 Landco Dr. Suite A
 Bakersfield, CA 93308
 Remit to: 10729 Wheatlands Ave. Suite C
 Santee, CA 92071

Sold To:

Exeter Police Department
 100 North C Street
 Exeter, CA 93221

Ship To:

Exeter Police Department
 100 North C Street
 Exeter, CA, 93221

Reference	PO Number	Customer No.	Salesperson	Order Date	Ship Via	Terms
2025 Patrol PIU x1 RevB (2026 Buil		EXE11001	AS	Apr 7, 2026	FEDEX	NET30

Year	Make	Model	Color	State Contract #
2025	Ford	PIU, EcoBoost	B/W	NA

Qty. Ord.	Item / Vendor Part Number	Description	Unit Price	Tax	Extended Price
2.00	FACE00624 / 15130	Blank Faceplate, 3/4"	0.0000	N	0.00
1.00	CONS00354 / C-ARM-104	Arm Rest, Adjustable PB 2012-09-01	255.2000	Y	255.20
2.00	CONS01276 / MMBP-25	Magnetic Microphone Mount	38.0000	Y	76.00
1.00	VACC01101 / 11010	DC Power Port	8.0000	Y	8.00
1.00	VACC01102 / 11011	DC Power Port Cap	2.0000	Y	2.00
1.00	VACC02798 / B08DD4BH6G	USB C & USB A Dual Port Car Charger Socket Power Outlet	26.0000	Y	26.00
1.00	LIGH00331 / M84434RW-A	6" LED Dome Light, Red/White, 110 Lumens	82.0000	Y	82.00
		Computer Mount (Getac F110)			
1.00	CONS01468 / 7160-0872	Offset Bracket Computer Mount is Customer Supplied ***Modem Install***	42.0000	Y	42.00

Quotation continued on next page ...				
---	--	--	--	--



Quotation

Date Apr 7, 2026	Page 8
Order Number QTE0043964	

AEP - California, LLC

3437 Landco Dr. Suite A
 Bakersfield, CA 93308
 Remit to: 10729 Wheatlands Ave. Suite C
 Santee, CA 92071

Sold To:

Exeter Police Department
 100 North C Street
 Exeter, CA 93221

Ship To:

Exeter Police Department
 100 North C Street
 Exeter, CA, 93221

Reference	PO Number	Customer No.	Salesperson	Order Date	Ship Via	Terms
2025 Patrol PIU x1 RevB (2026 Buil		EXE11001	AS	Apr 7, 2026	FEDEX	NET30

Year	Make	Model	Color	State Contract #
2025	Ford	PIU, EcoBoost	B/W	NA

Qty. Ord.	Item / Vendor Part Number	Description	Unit Price	Tax	Extended Price
1.00	COMP01877 / 31353	Cat7 Double Shielded Ethernet Cable, Black, 15' Note: Install Exeter Supplied Siera Wireless Modem -Modem on partition behind driver's seat ***Radio / Data Antenna***	18.0000	Y	18.00
1.00	ANTE01248 / GP-IN2850	Panorama Reef Sharkee - 7-IN-1 Low Pro Antenna Kit for R980	552.6300	Y	552.63
1.00	ANTE00782 / C23F-5M	Radio Antenna Extension Cable, 16', Mini-UHF (MPL)	17.2300	Y	17.23
1.00	ANTE00791 / AFGB-S4	Antenna Whip (Sharkee), UHF, 450-470 MHz ***Radio Install Parts***	33.7400	Y	33.74
1.00	SPEA00146 / GM-65/8	Radio Speaker, 5-1/4" 8 Ohm, Sealed Back w/ Grille	22.0000	Y	22.00
1.00	PATC00335 / PIU20-RADIO-KIT	Radio T/R Mounting Bracket, OEM Cubby Pocket, 20+ Utility ***Prisoner Transport***	43.6000	Y	43.60

Quotation continued on next page ...



Quotation

Date Apr 7, 2026	Page 9
Order Number QTE0043964	

AEP - California, LLC

3437 Landco Dr. Suite A
 Bakersfield, CA 93308
 Remit to: 10729 Wheatlands Ave. Suite C
 Santee, CA 92071

Sold To:

Exeter Police Department
 100 North C Street
 Exeter, CA 93221

Ship To:

Exeter Police Department
 100 North C Street
 Exeter, CA, 93221

Reference	PO Number	Customer No.	Salesperson	Order Date	Ship Via	Terms
2025 Patrol PIU x1 RevB (2026 Buil		EXE11001	AS	Apr 7, 2026	FEDEX	NET30

Year	Make	Model	Color	State Contract #
2025	Ford	PIU, EcoBoost	B/W	NA

Qty. Ord.	Item / Vendor Part Number	Description	Unit Price	Tax	Extended Price
1.00	PRIS01937 / PK11861TU20-TM	10XL C2 Partition, Recessed, Poly Sliding, Tall Man 20-25 PI	993.5200	Y	993.52
1.00	PRIS02563 / QK05661TU25	Transport Seat w/Poly Partition, Center Belts, 2025 Utility	1,547.9200	Y	1,547.92
1.00	PRIS01939 / WK05141TU20H	Window Barriers, Steel Horizontal Bars, 20-25 PIU	289.5200	Y	289.52
2.00	DOME00054 / E06-LS0R-1	Silho-X 4" Round Neutral White/Red Light SS Trim Ring	45.0000	Y	90.00
1.00	VACC01661 / AEP-SW-DOME3	Switch, Rear Dome Light, Color Select, On-On (Red-White)	28.8000	Y	28.80
1.00	VACC01450 / AEP-SW-DOME1	Switch, Rear Dome Light, On-Off-On (On-Door-Off)	28.8000	Y	28.80
		Front Gun Rack			
1.00	GUNM00862 / GRPXX6B1X238	Gun Rack Partition Mount SC6 with Insert SC1 #2 Key 38"	639.2000	Y	639.20
1.00	GUNM00513 / GUNMARTDPGRDBOM	AR-15 Takedown Pin Guard	192.0000	Y	192.00
		Rear Cargo Area			
1.00	VACC02123 / TK08411TU20	Setina 2 Drawer, Sliding, Top Combo Lock, Elevated, 2020 PIU	1,811.9200	Y	1,811.92

<i>Quotation continued on next page ...</i>					



Quotation

Date Apr 7, 2026	Page 10
Order Number QTE0043964	

AEP - California, LLC

3437 Landco Dr. Suite A
 Bakersfield, CA 93308
 Remit to: 10729 Wheatlands Ave. Suite C
 Santee, CA 92071

Sold To:

Exeter Police Department
 100 North C Street
 Exeter, CA 93221

Ship To:

Exeter Police Department
 100 North C Street
 Exeter, CA, 93221

Reference	PO Number	Customer No.	Salesperson	Order Date	Ship Via	Terms
2025 Patrol PIU x1 RevB (2026 Buil		EXE11001	AS	Apr 7, 2026	FEDEX	NET30

Year	Make	Model	Color	State Contract #
2025	Ford	PIU, EcoBoost	B/W	NA

Qty. Ord.	Item / Vendor Part Number	Description	Unit Price	Tax	Extended Price
2.00	DOME00045 / ECVDMLTST4G	Universal Interior Cargo LED Dome Light, 6"x3", Gray	32.0000	Y	64.00
1.00	VACC00342 / 13-100	Toggle Switch, Off-On, SPST..	19.2000	Y	19.20
1.00	VACC01453 / AEP-LABEL-CARGO-DO	Switch Label Plaque, "Cargo Dome, Door-Off"	14.4000	Y	14.40
1.00	LIGH00331 / M84434RW-A	6" LED Dome Light, Red/White, 110 Lumens	82.0000	Y	82.00
		Installation			
1.00	SHOP90006 / Shop Supplies	Shop Supplies: Wire, Loom, Connectors, Hardware...	100.0000	Y	100.00
46.00	LABO90001 / AEP INSTALL	All Labor Charges EVT-Certified Technician Labor	125.0000	Y	5,750.00
		Freight Shipping			
		Shipping		Y	150.00
		Customer Supplied Material			
1.00	INST05685 / CSM	Motorola APX-6500 Remote Head Radio Kit	0.0000	N	0.00
1.00	INST05685 / CSM	Sierra Wireless Modem	0.0000	N	0.00

Quotation continued on next page ...



Quotation

Date Apr 7, 2026	Page 11
Order Number QTE0043964	

AEP - California, LLC

3437 Landco Dr. Suite A
Bakersfield, CA 93308
Remit to: 10729 Wheatlands Ave. Suite C
Santee, CA 92071

Sold To:

Exeter Police Department
100 North C Street
Exeter, CA 93221

Ship To:

Exeter Police Department
100 North C Street
Exeter, CA, 93221

Reference	PO Number	Customer No.	Salesperson	Order Date	Ship Via	Terms
2025 Patrol PIU x1 RevB (2026 Buil		EXE11001	AS	Apr 7, 2026	FEDEX	NET30

Year	Make	Model	Color	State Contract #
2025	Ford	PIU, EcoBoost	B/W	NA

Qty. Ord.	Item / Vendor Part Number	Description	Unit Price	Tax	Extended Price
1.00	INST05685 / CSM	GJ 7160-0542-03 TabCruiser Dock for Getac F110	0.0000	N	0.00
1.00	INST05685 / CSM	Lind Power Supply for F110 TabCruiser Dock	0.0000	N	0.00
1.00	INST05685 / CSM	Getac GDKBU9 Keyboard	0.0000	N	0.00
1.00	INST05685 / CSM	Getac F110 Tablet Computer	0.0000	N	0.00
1.00	INST05685 / CSM	GJ 7160-1973, On-Dash Mounting Bracket	0.0000	N	0.00
1.00	INST05685 / CSM	GJ 7160-2000-09, Mongoose Motion / Clevis	0.0000	N	0.00
1.00	INST05685 / CSM	GJ 7160-0857 Keyboard Tray	0.0000	N	0.00

Thank you for the opportunity to earn your business	Parts	20,625.65
Terms & Conditions:	Labor / Services	5,750.00
<ul style="list-style-type: none"> • ESTIMATES VALID FOR 30 DAYS • Orders will be invoiced upon notification of completion • Returns subject to 25% restocking fee. No returns on special order items. • Credit Card payments accepted for payments of orders/invoicing totaling \$10,000 or less only. 	Trans / Trip / Fee	0.00
SIGNATURE (not required if PO/contract is issued) _____	Shipping	150.00
	Order Discount	0.00
	Subtotal	26,525.65
	Total sales tax	2,310.11
	Total order	28,835.76



Exeter Police

Lighting Package, Patrol / K9 Utility (2025+)

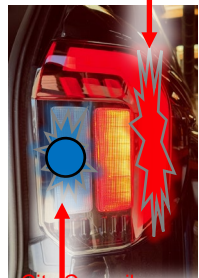
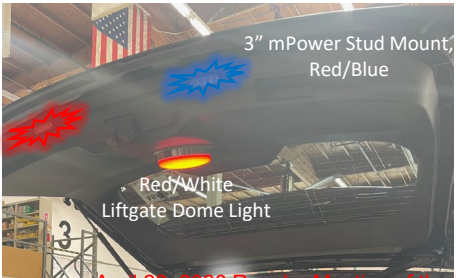
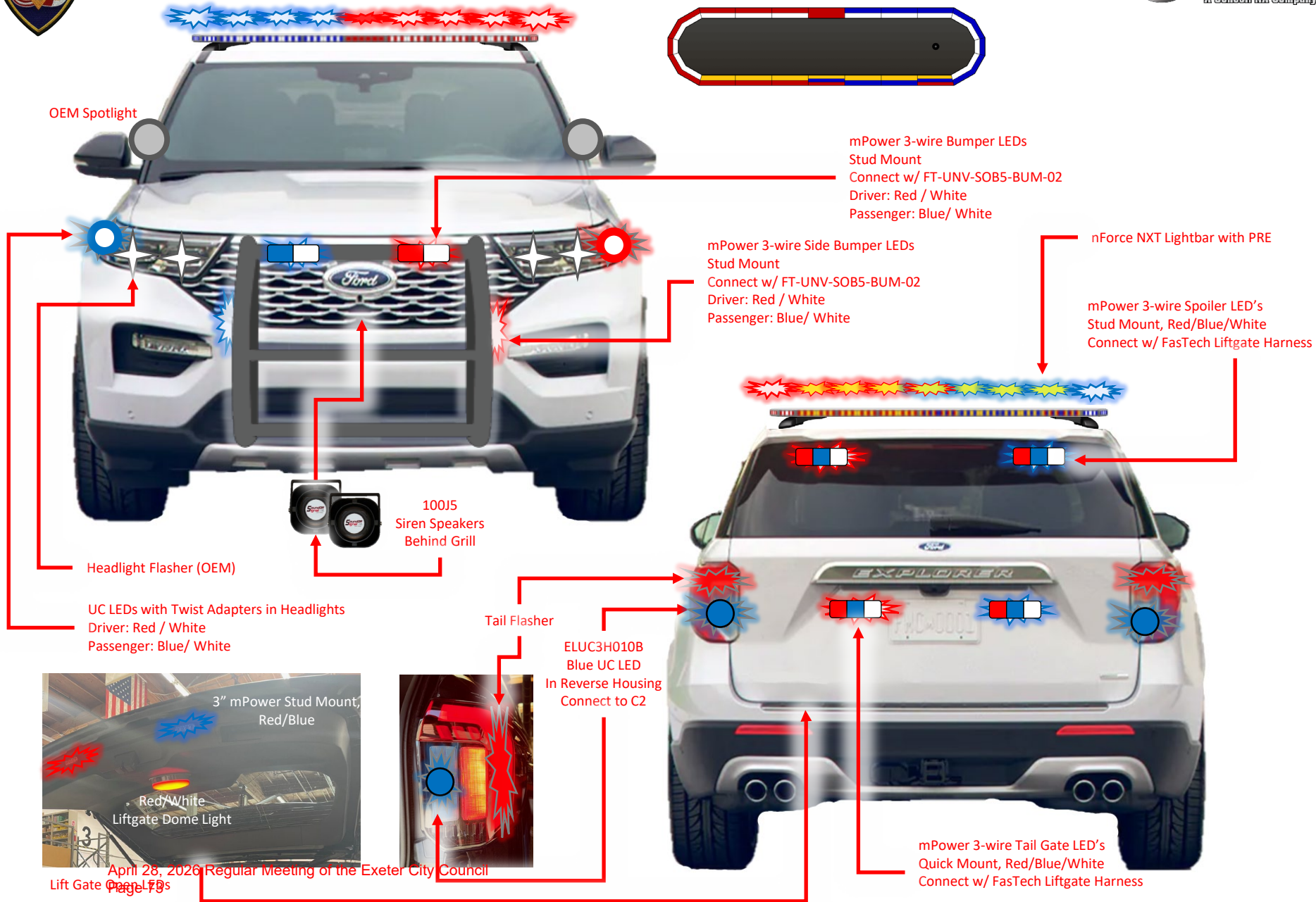



Exeter Police

Lighting Package, Patrol / K9 Utility (2025+)



SoundOff nForce NXT
Multi-Color LED Lightbar

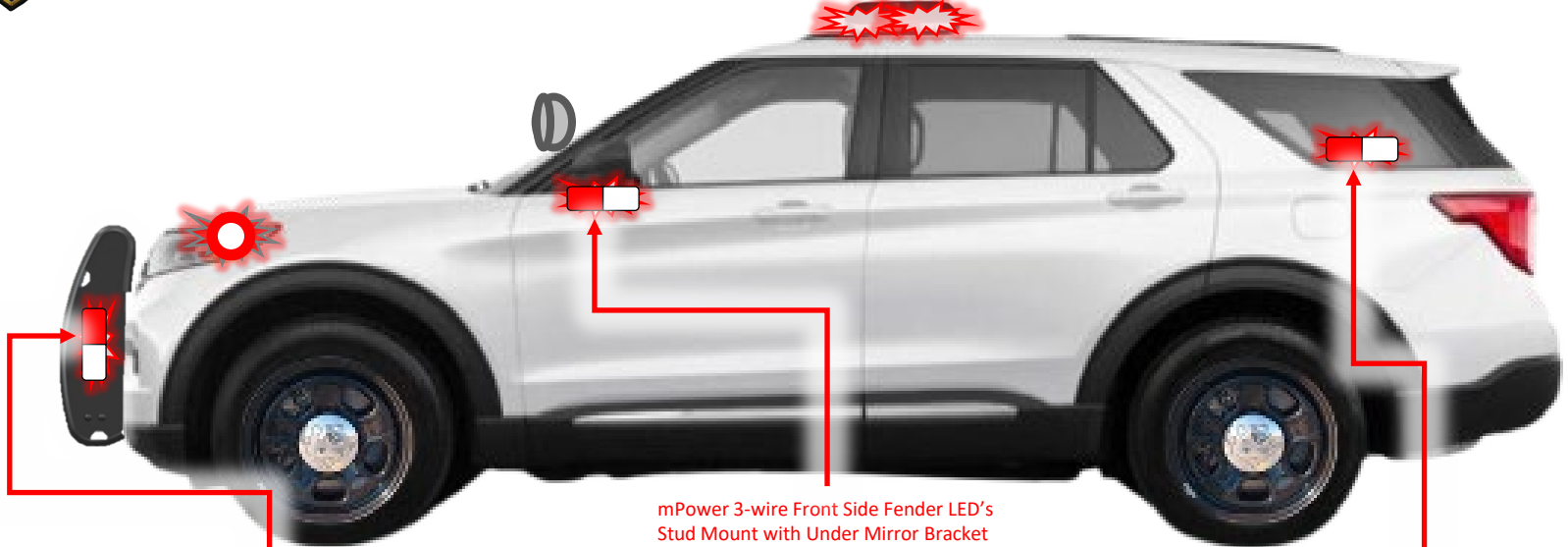

mPower 3-wire Side Bumper LED's
Stud Mount
Connect w/ FT-UNV-SOB5-BUM-02
Driver: Red / White
Passenger: Blue/ White

mPower 3-wire Front Side Fender LED's
Stud Mount with Under Mirror Bracket
Connect with FT-UNV-SOB5-3WR-03
Driver: Red / White
Passenger: Blue/ White

mPower 3-wire Rear Side Fender LED's
Stud Mount with Glass Mount Shroud
Connect with FT-UNV-SOB5-3WR-03
Driver: Red / White
Passenger: Blue/ White



UC LEDs with Twist Adapters in Headlights
Driver: Red / White
Passenger: Blue/ White



Exeter Police

Exterior mPower Lightbar, PATROL, K9, SGT

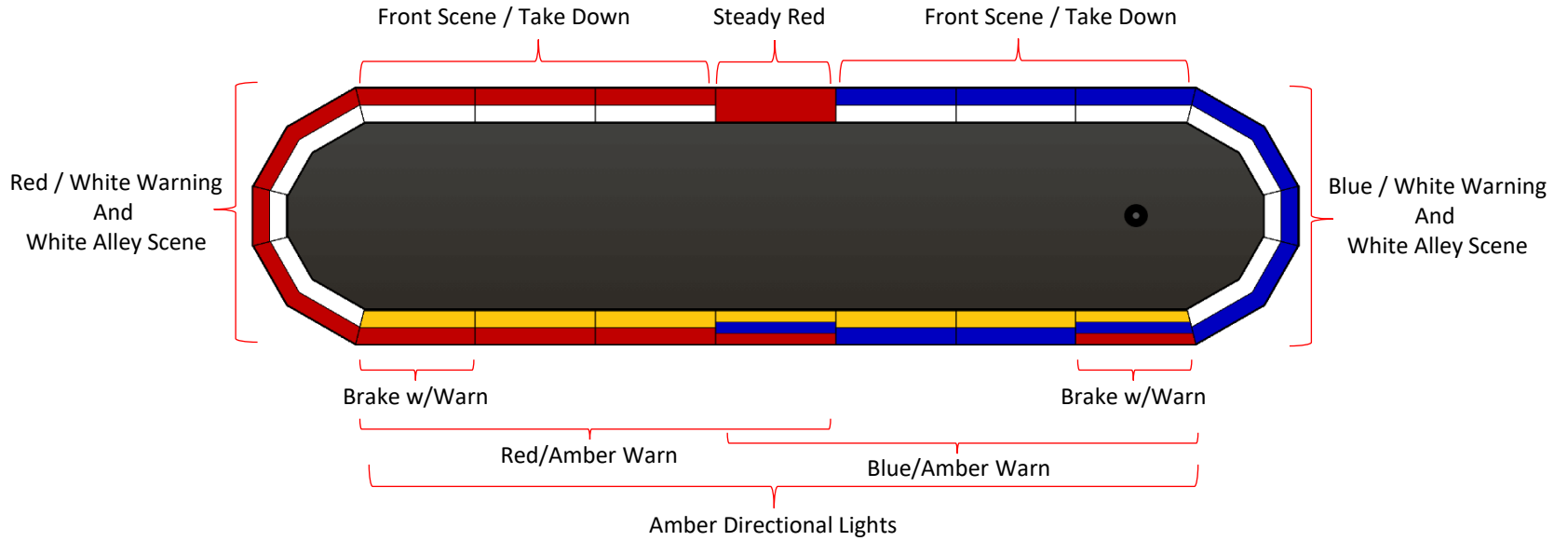

Front



Rear



Exeter Police

Lighting Operation- Auxiliary Lights / Switches



RADIO REBROADCAST: Broadcasts 2-way radio audio through PA
HORN: Activates "Air Horn" tone
MANUAL: Activate "Manual" tone. (Raise and fall "Wail")



Siren:

- Vehicle must be in "Drive" gear and in "Level 3" Lighting
- Siren can be activated from steering when horn switch

STANDBY: Turns OFF siren
WAIL: Dual tone "Wail" siren
YELP: Dual tone "Yelp" siren
TONE: Dual tone "Wail" and "Yelp" siren



Auxiliary Switches:



Directional Light: Controls the directional arrow light. The rear facing warning lights will burn steady blue when arrow functions are active. The arrow will automatically cancel when the vehicle is shifted from "park" to "drive"

- Press 1: Left Arrow
- Press 2: Right Arrow
- Press 3: Center Out Arrow
- Press 4: Off



Left Alley / Scene: Controls the left alley and scene light functions.

- Press 1: Light bar alley light
- Press 2: Left scene light (all left facing LED's in white mode)
- Press 3: Off



Take Down / Scene: Controls the take down and front scene light functions.

- Press 1: Light bar take down lights
- Press 2: Front scene light.
- Press 3: Off



Right Alley / Scene: Controls the right alley and scene light functions.

- Press 1: light bar alley light
- Press 2: Right scene light (all right facing LED's in white mode)
- Press 3: Off



Hi-Lo Emergency Evacuation: Activates Evacuation Notice with HiLo Siren Tone. (SB-909)

- Voice announcement plays on external speaker
- Message cycles until deactivated by button.



Scene: Activates full 360-degree white scene lighting with single button press.

- Activates right spot if vehicle is in "park"



Spot: Activates the right post mounted spotlight. This button is also activated by front scene when in "Park"



Gun: Releases the front weapon rack for 8 seconds.

- 2-button security operation. Press "GUN" button then press "STANDBY" button.
- Key MUST be in the ignition switch, in "on" position
- Weapon locks will release for 8-seconds



Exeter Police

Lighting Operation- Auxiliary Lights / Switches



RADIO REBROADCAST: Broadcasts 2-way radio audio through PA
HORN: Activates "Air Horn" tone
MANUAL: Activate "Manual" tone. (Raise and fall "Wail")



Siren:

- Vehicle must be in "Drive" gear and in "Level 3" Lighting
- Siren can be activated from steering when horn switch

STANDBY: Turns OFF siren
WAIL: Dual tone "Wail" siren
YELP: Dual tone "Yelp" siren
STONE: Dual tone "Wail" and "Yelp" siren



Auxiliary Switches:

Directional Light: Controls the directional arrow light. The rear facing warning lights will burn steady blue when arrow functions are active. The arrow will automatically cancel when the vehicle is shifted from "park" to "drive"

- Press 1: Left Arrow
- Press 2: Right Arrow
- Press 3: Center Out Arrow
- Press 4: Off



Left Alley / Scene: Controls the left alley and scene light functions.

- Press 1: Light bar alley light
- Press 2: Left scene light (all left facing LED's in white mode)
- Press 3: Off



Take Down / Scene: Controls the take down and front scene light functions.

- Press 1: Light bar take down lights
- Press 2: Front scene light.
- Press 3: Off



Right Alley / Scene: Controls the right alley and scene light functions.

- Press 1: light bar alley light
- Press 2: Right scene light (all right facing LED's in white mode)
- Press 3: Off



Hi-Lo Emergency Evacuation: Activates Evacuation Notice with HiLo Siren Tone. (SB-909)

- Voice announcement plays on external speaker
- Message cycles until deactivated by button.



Scene: Activates full 360-degree white scene lighting with single button press.

- Activates right spot if vehicle is in "park"



Spot: Activates the right post mounted spotlight. This button is also activated by front scene when in "Park"



Gun: Releases the front weapon rack for 8 seconds.

- 2-button security operation. Press "GUN" button then press "STANDBY" button.
- Key MUST be in the ignition switch, in "on" position
- Weapon locks will release for 8-seconds

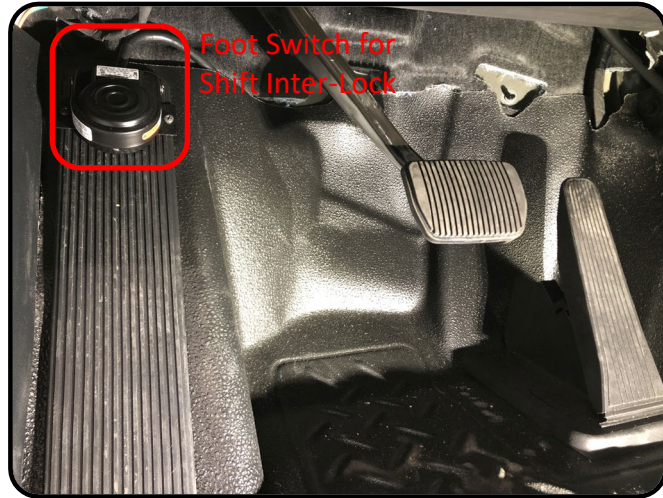

Shift Inter-Lock System

- The shift interlock system (Optional) prevents the gear selector (shifter) from shifting out of “park” unless the foot switch is depressed. (3 second activation)
- The shifter will remain “enabled” for:
 - 3 seconds after pressing the foot switch
 - 60 seconds after the vehicle is shifted from “drive” to “park”
- This two-action requirement is designed to prevent unauthorized use.
- The system is enabled when the master Patrol Power/ siren system is “On”. If the vehicle is “in-service” the shift-interlock is enabled. The shifter will return to normal OEM operation when the master switch is “Off”. This allow the vehicle to be serviced at the dealership/car washes without “giving away the secret”



Exeter Police

Special and Automated Features



bluePRINT SYNC:

- bluePRINT SYNC (when equipped) will unify the lighting functions of all sync equipped vehicles across the fleet.
- Provides true warning system coordination between vehicles
- Sync-equipped vehicles will automatically flash in perfect timing with each other
- Sync reduces the distractions and confusion of multiple, random flashing lights. Approaching drivers can better judge the emergency vehicle's status.
- Sync enhances the professional image of all warning or response vehicles on a scene
- Sync enhances the tactical presence of police by calming scenes and implying control



Brake with Warn:

- Automatically changes the lighting signal to the rear of the vehicle for heightened "braking awareness"
- "Brake with Warn" is enabled when warning lights are on (1,2 or 3) and the vehicle is above 15 MPH
- "Flicker Brake" of select lightbar modules and under spoiler LED's. Other lights will have reduced intensity or be momentarily deactivated
- Feature avoids the OEM brake lights from being un-noticed by the brighter warning lights.



Lightbar Corner Module Disable:

- To preserve the officer's vision the lightbar corner modules will be disabled when either the driver or passenger side doors are open respectively.
- The driver's door will keep the driver's corner module deactivated for 15 seconds after the door is closed, allowing time to make a safe approach
- All modules will return to normal operation immediately when the vehicle is shifted into any drive gear.



Reverse White Lighting:

- The rear under spoiler LED's and the rear side ¼ glass LED's will automatically activate in white reverse mode when the vehicle is in "reverse"



Arrow with Turn Signal:

- The left and right lightbar directional arrow will activate with the turn signals while in level 1,2 or 3 when the transmission is also in "park" position.
- This is to allow arrow activation via steering wheel controls to maintain eye contact with suspect vehicles during traffic stops.



Control Panel Backlighting:

- The control panel backlighting will closely match the instrument cluster illumination ranging from off, low, medium and high.



System Timer:

- The lighting control system, radio and other accessories will remain active for 30 minutes after the ignition is turned off.
- The computer / model will remain active for 1 hours if voltage is above 11.5V.
- Prevents dead batteries



Master Breaker: (Accessibly Located Under Driver's Seat)

- All aftermarket equipment will be disconnected from the vehicle / battery
- Open (Off) the breaker in vehicle will be removed from service for an extended period, or driven by an unauthorized user
- The Shift Inter-Lock security system will be bypassed when the master breaker is open (Off). (Keeps the secret- a secret)



Driver Seat

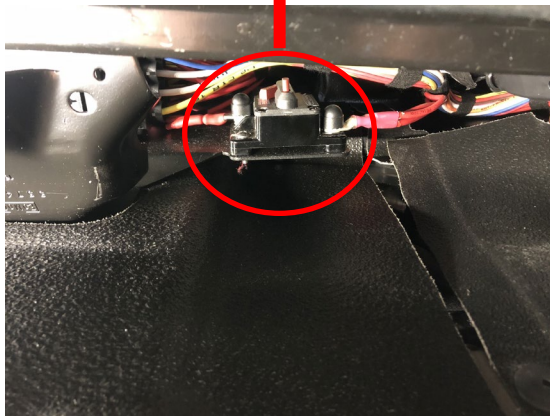

Master Breaker / Disconnect Switch

What it does:

- Disconnects all aftermarket equipment from the vehicle battery.
- The Shift Inter-Lock security system will be bypassed when the master breaker is open (Off).
 - (Keeps the secret- a secret)

When to use it:

- Disconnect (open breaker) when vehicle will be place “out of service” for an extended period.
- Disconnect when vehicle will be operated by a person not authorized to use emergency / radio equipment
- Disconnect when vehicle is being serviced / at car wash

How to use:

- Locate the breaker under the driver’s seat.
- Press blue button to “open” breaker (disconnect)
- Push yellow bar towards center of breaker to “close” (connect)



“Closed”
Connected / ON



“Open”
Disconnected / OFF



Exeter Police

Ford PI Utility, Console Package w/ Getac F120

Getac F120

(All New AEP Supplied)



7160-2127-14
Getac F120 Dock
w/ Power Supply



Gamber Johnson
7160-0872



Gamber Johnson 7160-1346-01
On-Dash Bracket

Refer to next slide for this build

GDKBU9
Getac Keyboard



7160-0857
Quick Release Mount



Mongoose XLE 9"
7160-2000-09



Mag Mic Mount (Radio)



12VDC/
USB



10" Sloped

15130
.75" Blank

7160-0321
APX/XTL, 3"

15130
.75" Blank

14619
SoundOff
Control Panel, 3.5"

15083
Switch Plate, 2"



Mag Mic Mount (PA)



Dual Cup Holder
(Console Package)

Parking Brake Re-Location

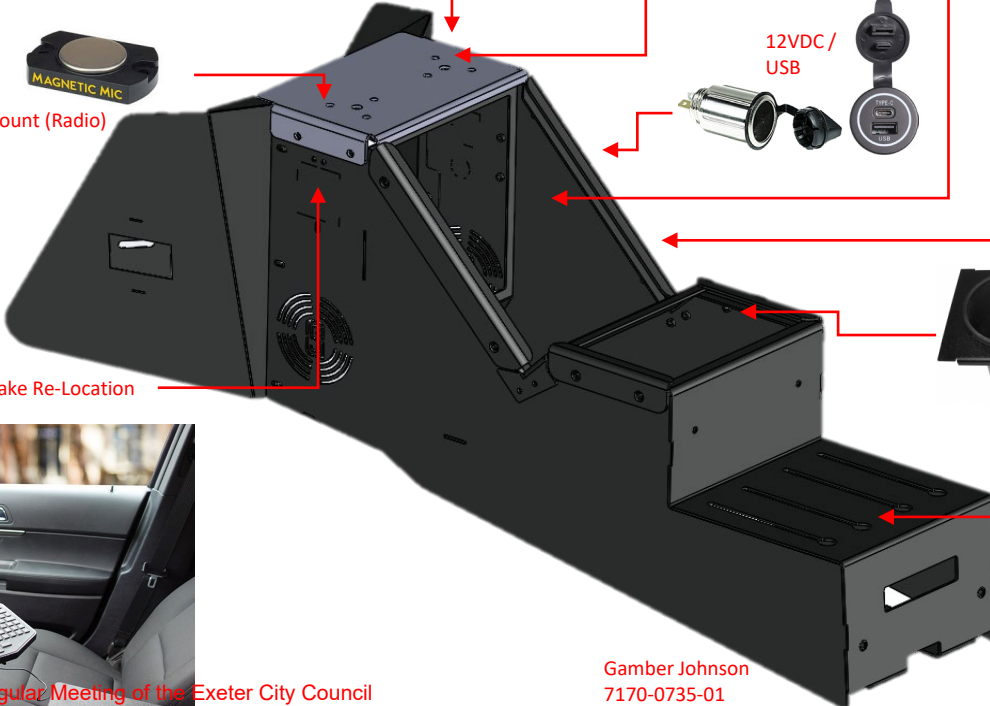

Havis C-ARM-104
Arm Rest

Gamber Johnson
7170-0735-01
Console Kit (Short)





Exeter Police

Antenna Configuration- 2025 APX



Getac F120

(All New AEP Supplied)



Modem
On Partition
(Behind Pass Seat)

Antenna Whip:
Panorama AFGB-S4
UHF Antenna Whip
450-470MHz

Antenna Base:
Panorama GP-IN2850
Reef Shark 7-in-1 (+ Radio Whip)

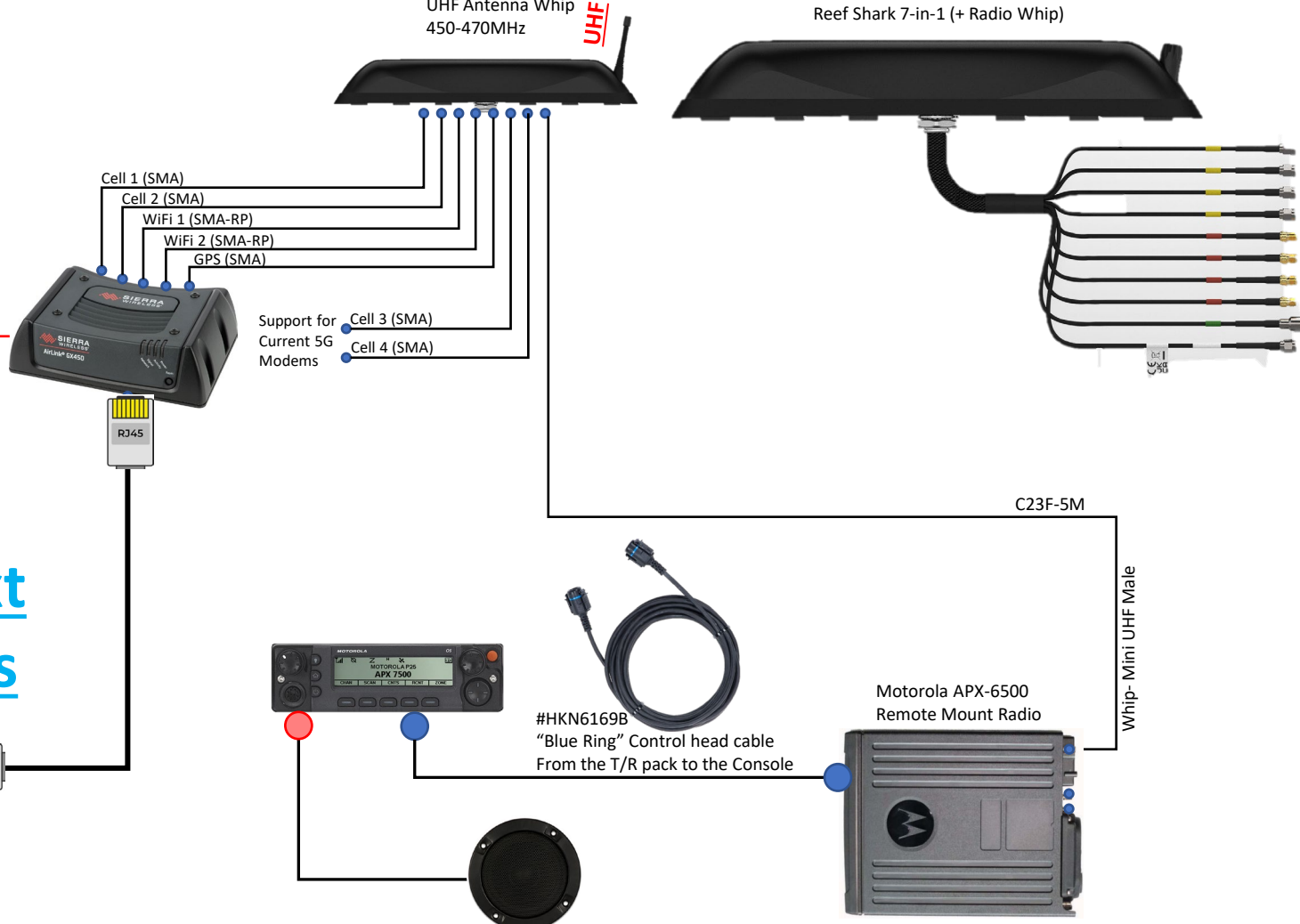

Refer to next slide for this build



Getac F120
Docking Station

Headliner Mounted
Radio Speaker



Exeter Police

Ford PI Utility, Console Package w/ Getac F110

Getac F110 (Exeter Supplied)



AEP

A Sonel USA Company





Exeter Police

Antenna Configuration- 2025 APX

Getac F110 (Exeter Supplied)



Modem
On Partition
(Behind Pass Seat)

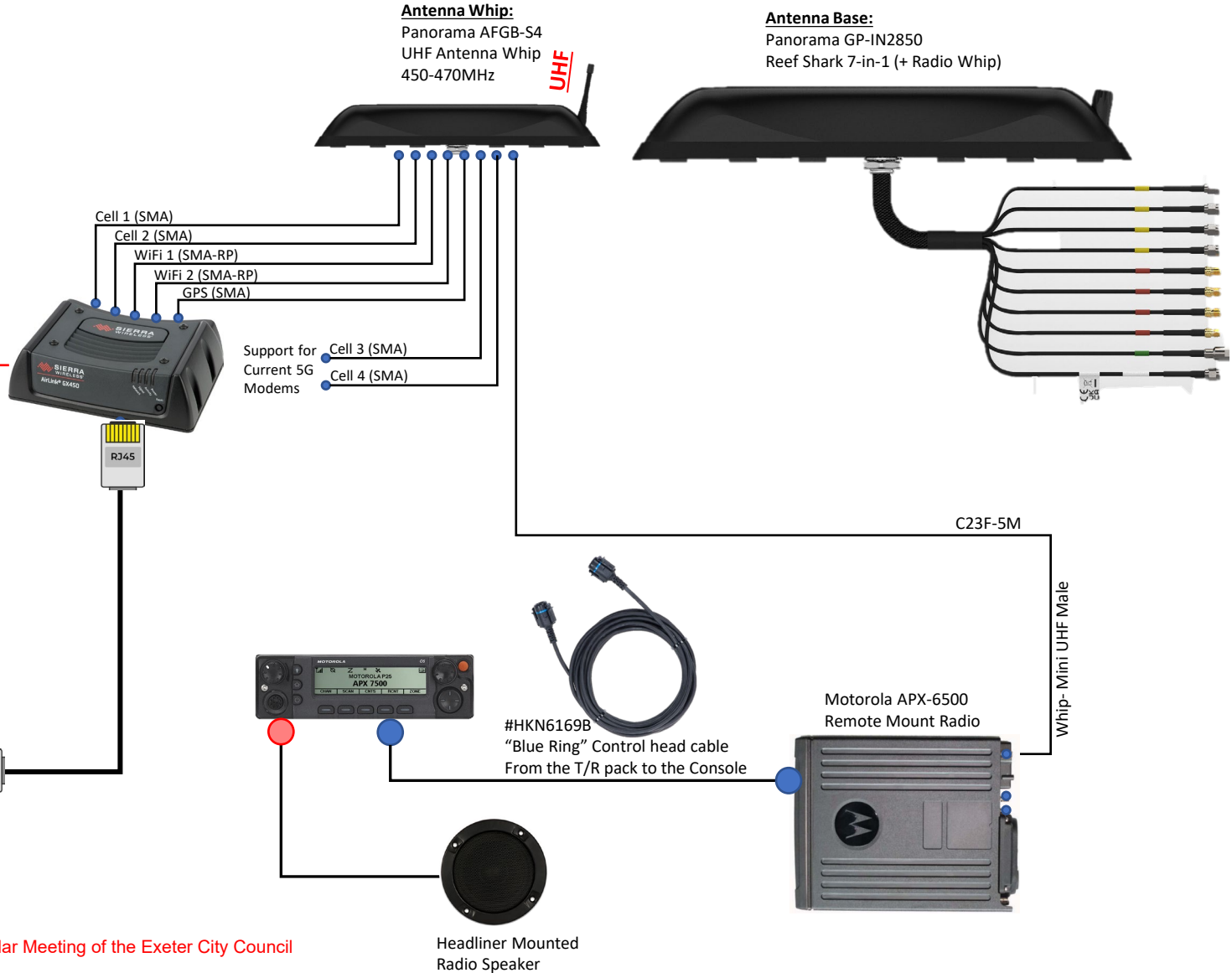

Getac F110
Gamber Johnson 7160-0542-03



Exeter Police

Headliner Radio Speaker- Ford Utility



Required Components

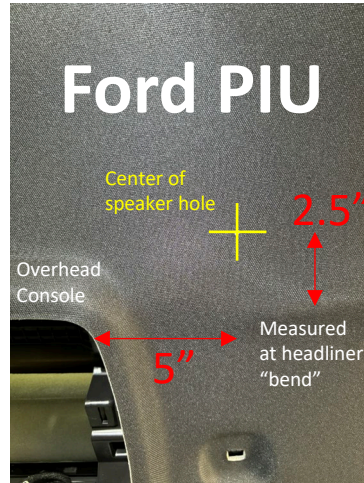

Step 1: Using an Awl, measure and mark the center of the speaker hole.

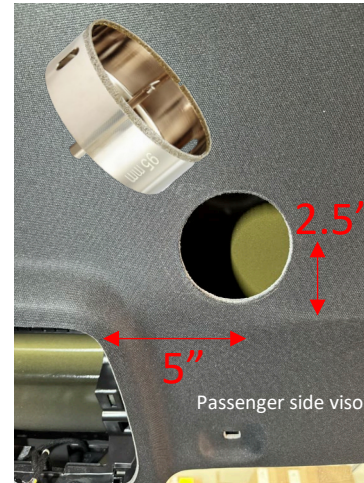

Step 2: Cut speaker hole using a 95mm diamond grit (tile) hole saw. Use care to not allow the hole saw to "walk"

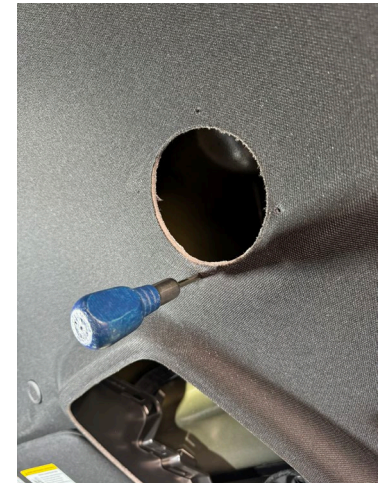

Step 3: Using the speaker and an awl, punch the holes for the 8-32 screws



Step 4: Apply strip caulk to backer plate. (Prevents face of plate from butting against metal roof. Strip caulk face down towards headliner)



Step 5: Apply fuzzy side Velcro to back of speaker. (prevents rattles on roof)

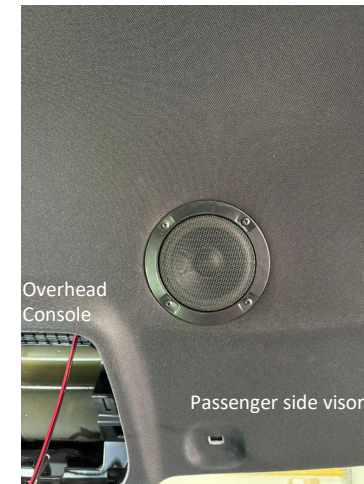

Step 6: Position backer ring behind headliner, held in place with strip caulk. Install speaker

[Insert video QR code here](#)



Exeter Police

Roof/Antenna Layout 2020 PI Utility



AEP
A Sencel HA Company

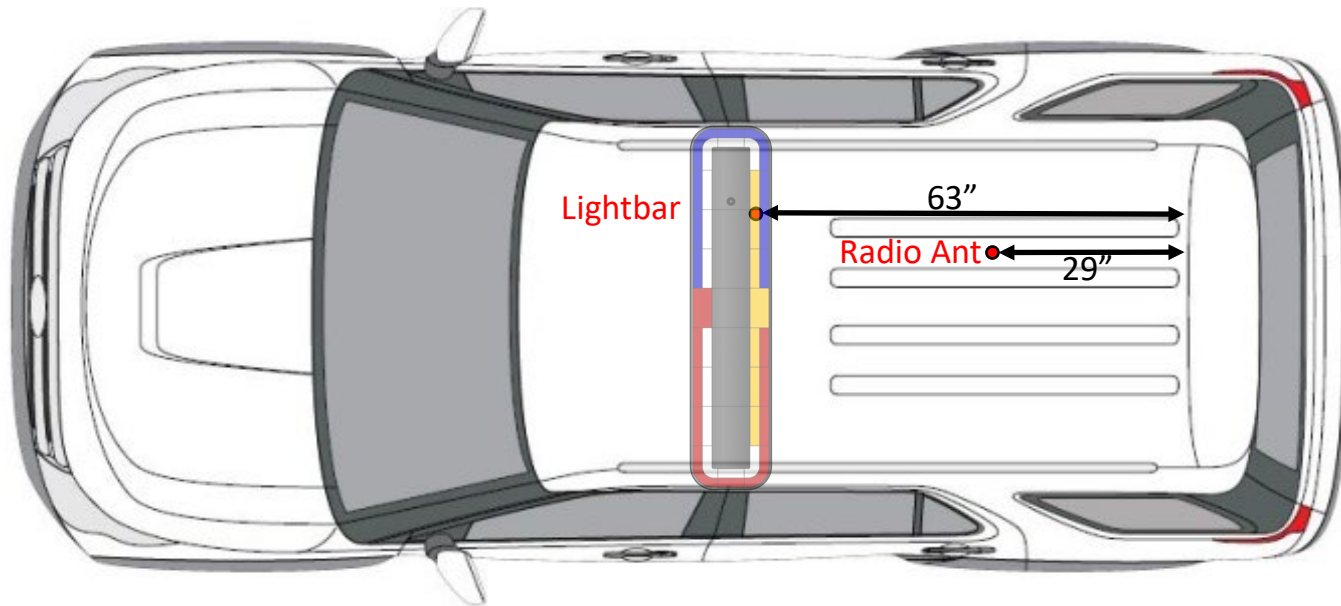



Exeter Police

Ford PI Utility, Transportation System



Setina PK1186ITU20-TM
10XL C2 Partition, Recessed, C Poly Sliding window, Tall Man Installation Kit

(Offers maximum leg room for officer and detainee)



Setina WK0514ITU20H
Steel Horizontal Window Barriers



Patrol Power FRD200001-0
Rear Door Block-Off Plates



Setina 12-VS
Rear Cargo Partition with Polycarbonate Window *(Included with transport seat)*



Red/White Combo



Prisoner Dome Lights
With console mounted control switch

- On-** Force dome lights on
- Door-** Lights turn on/off with rear doors
- Off-** Force dome lights off



- White-** White Light
- Red-** Red Light for night visibility



Setina QK0566ITU20
Full Replacement Prisoner Transport Seat with Center-Pull Seat Belts

(Offers maximum leg room for officer and detainee)



Center pull seat belts allow officer to buckle seat belt from outboard position to prevent leaning over occupants



Seat belts buckle to partition when not in use



Exeter Police

Ford PI Utility, Partition Mounted Weapon Mount (Patrol)



Rifle / UPR:

- Barrel lock mount for various weapon configurations
- Adjustable lock position
- Magnetic bypass protection
- Take-Down pin guard for added security



Shotgun / 870:

- Lock secure weapon and prevents the action cycling
- Adjustable lock position
- Magnetic bypass protection





Exeter Police

Ford PI Utility, Rear Storage Solution



KEY PAD

Electronic Self Containing Lock

- Keyless Entry
- Electronic Override
- Single Piece Design for easy, no-wire integration
- Programming key offers simple, quick enrollment
- LED Indicator



Requires free-standing base when not used with #12VS rear partition.





Exeter Police

Lightbar Install, nFuse / NXT on Utility

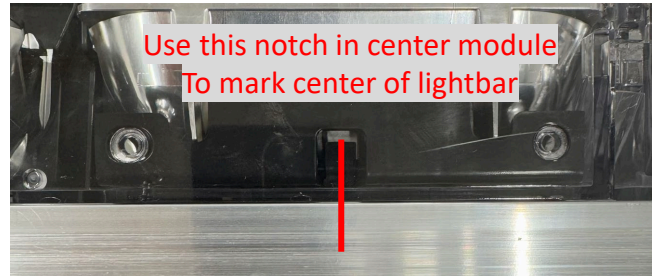

Hook Kit Centered on Door Jamb

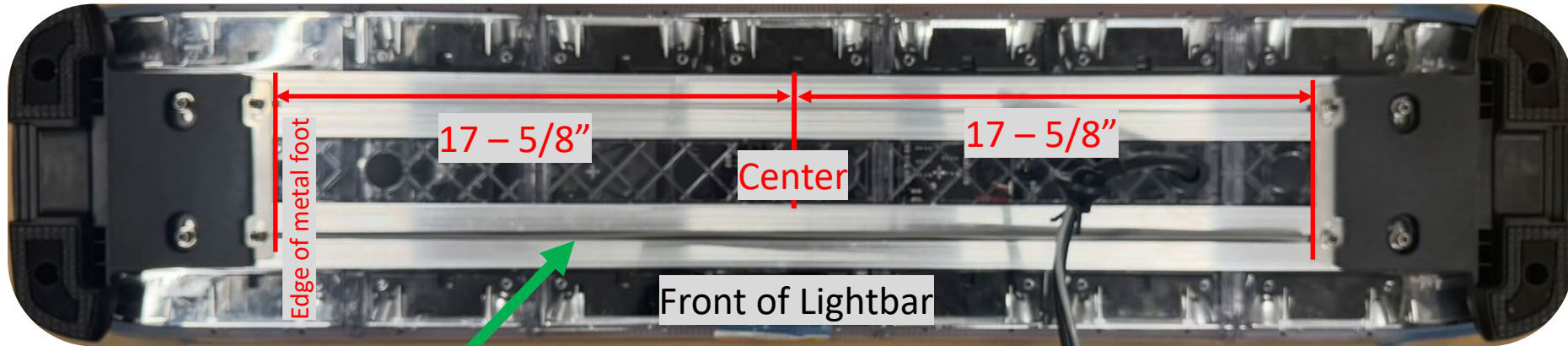

Install Rubber Air Dam Strip In Forward Edge Bolt Channel



Use OEM grommet located in glovebox





Exeter Police

mPower 3-Wire with FasTech Harness, SUV's



AEP
A Sencel HA Company

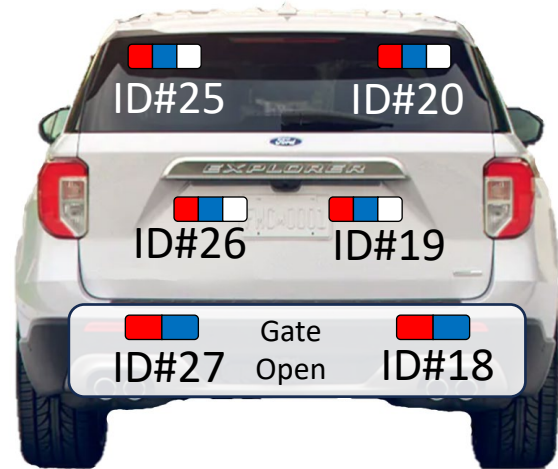
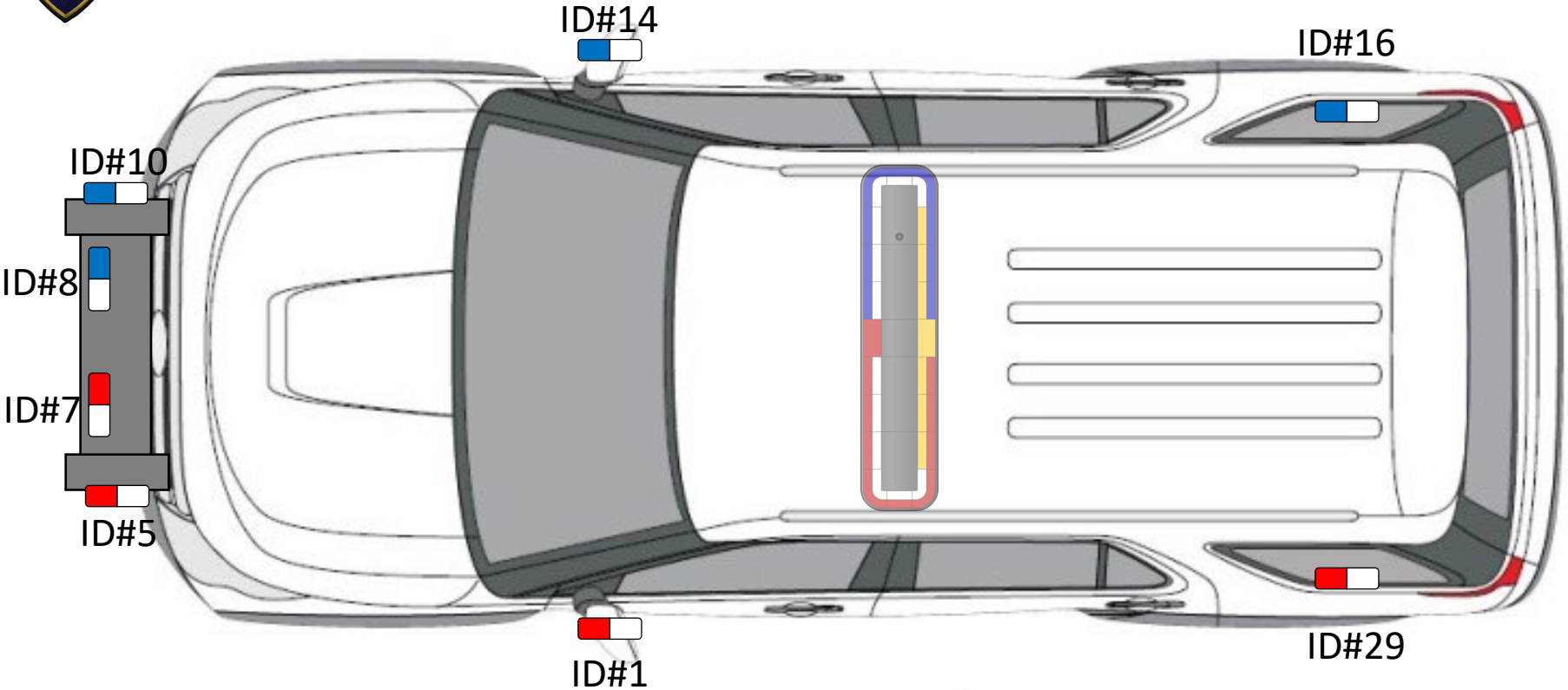

DANA SAFETY SUPPLY, INC
 500 S EDWARDIA DR
 GREENSBORO, NC 27409

Sales Quote

Telephone: 800-845-0045

Sales Quote No.	623945
Customer No.	EXTERPD-CA

Bill To

Exeter Police Department
 100 N C St
 Exeter, CA 93221

Ship To

(For Pickup - FRES)
 FRESNO WAREHOUSE
 2550 S East Ave Ste 120
 Fresno, CA 93706

Contact: Lt. Rob Moore
 Telephone: 559.592.3103
 E-mail: rmoore@exeterpd.com

Contact: Andy Llanez
 Telephone: (559) 420-7057
 E-mail:

Quote Date	Ship Via	F.O.B.	Customer PO Number	Payment Method	
04/13/26	UPS GROUND FREIGHT	FREIGHT ON BOARD		NET30	
Entered By	Salesperson	Ordered By	Resale Number		
Patrick Hope	Pat Hope- Fresno				
Order Quantity	Approve Quantity	Tax	Item Number / Description	Unit Price	Extended Price
1	1	N	INFO 2025 Ford PIU Warehouse: FRES	0.0000	0.00
1	1	Y	EVP EMERGENCY VEHICLE PACKAGE Warehouse: FRES	16,969.0000	16,969.00
1	1	N	INFO Front Facing - Activate OEM HL Flasher Warehouse: FRES	0.0000	0.00
1	1	Y	BK2168ITU20 SMC PB450L With SOUNDOFF SIGNAL MPOWER Warehouse: FRES Delivery Info: 710365	0.0000	0.00
1	1	Y	ETSS100J SOI 100J SERIES COMPOSITE SPEAKER Warehouse: FRES 100J series composite speaker w/ universal bail brkt-100 watt Delivery Info: 710366	0.0000	0.00
1	1	Y	MISC Soundoff mpower light bar RWBW/RABA Warehouse: FRES Mount on front bumper	0.0000	0.00
1	1	N	INFO Side Facing Warehouse: FRES	0.0000	0.00

Print Date	04/13/26
Print Time	05:53:22 PM
Page No.	1

DANA SAFETY SUPPLY, INC
 500 S EDWARDIA DR
 GREENSBORO, NC 27409

Sales Quote

Telephone: 800-845-0045

Sales Quote No.	623945
Customer No.	EXTERPD-CA

Bill To

Exeter Police Department
 100 N C St
 Exeter, CA 93221

Ship To

(For Pickup - FRES)
 FRESNO WAREHOUSE
 2550 S East Ave Ste 120
 Fresno, CA 93706

Contact: Lt. Rob Moore
 Telephone: 559.592.3103
 E-mail: rmoore@exeterpd.com

Contact: Andy Llanez
 Telephone: (559) 420-7057
 E-mail:

Quote Date	Ship Via	F.O.B.	Customer PO Number	Payment Method	
04/13/26	UPS GROUND FREIGHT	FREIGHT ON BOARD		NET30	
Entered By	Salesperson	Ordered By	Resale Number		
Patrick Hope	Pat Hope- Fresno				
Order Quantity	Approve Quantity	Tax	Item Number / Description	Unit Price	Extended Price
2	2	Y	ENT3B3RBW Delivery Info: 710366 SOI INTERSECTOR 18-LED SFC MNT,BLK HSG RED/BLUE/WHITE Warehouse: FRES Mount under sideview mirrors	0.0000	0.00
1	1	Y	PMP2BKUMB8-P Delivery Info: O.H SOI UNDER MIRROR MOUNT BRACKET KIT, PASS., 2025 PIU Warehouse: FRES Under Mirror Mount Bracket Kit (each) for installation on Ford PI Utility 2025 for use with mpower® 3" and 4" Stud and Intersector Surface Mount, Passenger Side	0.0000	0.00
1	1	Y	PMP2BKUMB8-D Delivery Info: O.H SOI UNDER MIRROR MOUNT BRACKET KIT, DRIVER, 2025 Warehouse: FRES Under Mirror Mount Bracket Kit (each) for installation on Ford PI Utility 2025 for use with mpower® 3" and 4" Stud and Intersector Surface Mount, Driver Side	0.0000	0.00
1	1	N	INFO rear facing Warehouse: FRES	0.0000	0.00

Print Date	04/13/26
Print Time	05:53:22 PM
Page No.	2

DANA SAFETY SUPPLY, INC
 500 S EDWARDIA DR
 GREENSBORO, NC 27409

Sales Quote

Telephone: 800-845-0045

Sales Quote No.	623945
Customer No.	EXTERPD-CA

Bill To

Exeter Police Department
 100 N C St
 Exeter, CA 93221

Ship To

(For Pickup - FRES)
 FRESNO WAREHOUSE
 2550 S East Ave Ste 120
 Fresno, CA 93706

Contact: Lt. Rob Moore
 Telephone: 559.592.3103
 E-mail: rmoore@exeterpd.com

Contact: Andy Llanez
 Telephone: (559) 420-7057
 E-mail:

Quote Date	Ship Via	F.O.B.	Customer PO Number	Payment Method	
04/13/26	UPS GROUND FREIGHT	FREIGHT ON BOARD		NET30	
Entered By	Salesperson	Ordered By	Resale Number		
Patrick Hope	Pat Hope- Fresno				
Order Quantity	Approve Quantity	Tax	Item Number / Description	Unit Price	Extended Price
4	4	Y	EMPS2QMS5RBW Delivery Info: 710366 SOI, MPWR FASCIA, 4", QM, BLK HSG, RED/BLU/WHT Warehouse: FRES mpower® 4" Fascia Light w/ Quick Mount, 18" hard wire w/ sync option, SAE Class 1 & CA Title 13, 9-32 Vdc, Black Housing, 18 LED, Tricolor - Red/Blue/White	0.0000	0.00
2	2	Y	2 by license plate 2 under rear hatch EMPS2STS5RBW Delivery Info: 710366 SOI, MPWR FASCIA, 4", STM, BLK HSG, RED/BLU/WHT Warehouse: FRES mpower® 4" Fascia Light w/ Stud Mount, 18" hard wire w/ sync option, SAE Class 1 & CA Title 13, 9-32 Vdc, Black Housing, 18 LED, Tricolor - Red/Blue/White	0.0000	0.00
2	2	Y	Rear Cargo Sides PMP2WSSSB Delivery Info: 710366 SOI 4" MPOWER SINGLE WINDOW SHROUD-BLACK Warehouse: FRES	0.0000	0.00
1	1	Y	ELUC3H010D Delivery Info: O.H SOI UNIV UNDERCOVER LED INSERT, 5 WIRE RED/WHITE Warehouse: FRES mount in reverse lights	0.0000	0.00

Print Date	04/13/26
Print Time	05:53:22 PM
Page No.	3

DANA SAFETY SUPPLY, INC
 500 S EDWARDIA DR
 GREENSBORO, NC 27409

Sales Quote

Telephone: 800-845-0045

Sales Quote No.	623945
Customer No.	EXTERPD-CA

Bill To

Exeter Police Department
 100 N C St
 Exeter, CA 93221

Ship To

(For Pickup - FRES)
 FRESNO WAREHOUSE
 2550 S East Ave Ste 120
 Fresno, CA 93706

Contact: Lt. Rob Moore
 Telephone: 559.592.3103
 E-mail: rmoore@exeterpd.com

Contact: Andy Llanez
 Telephone: (559) 420-7057
 E-mail:

Quote Date	Ship Via	F.O.B.	Customer PO Number	Payment Method	
04/13/26	UPS GROUND FREIGHT	FREIGHT ON BOARD		NET30	
Entered By	Salesperson	Ordered By	Resale Number		
Patrick Hope	Pat Hope- Fresno				
Order Quantity	Approve Quantity	Tax	Item Number / Description	Unit Price	Extended Price
1	1	Y	ELUC3H010E Delivery Info: O.H SOI UNIV UNDERCOVER LED INSERT, 5 WIRE BLUE/WHITE Warehouse: FRES mount in reverse lights	0.0000	0.00
1	1	N	INFO Roof Equipment Warehouse: FRES Customer supplied antennas or mounts and cabling	0.0000	0.00
1	1	N	INFO Siren Warehouse: FRES	0.0000	0.00
1	1	Y	ENGSA5100RSP Delivery Info: 710366 SOI, 500 SERIES PUSHBTN 100W CNTRL, +VOICE PLBK Warehouse: FRES	0.0000	0.00
1	1	Y	ENGLMK013 Delivery Info: O.H SOI BP LINK KIT, SUPER DUTY, '24 F150, '25 PIU Warehouse: FRES	0.0000	0.00
1	1	Y	ENGSYMD01 Delivery Info: 710366 SOI SOUND OFF / BLUEPRINT SYNC MODULE Warehouse: FRES	0.0000	0.00
2	2	Y	ENGND04102 Delivery Info: 710366 SOI 10 OUTPUT REMOTE NODE W/ MAGNETIC I.D. Warehouse: FRES	0.0000	0.00

Print Date	04/13/26
Print Time	05:53:22 PM
Page No.	4

DANA SAFETY SUPPLY, INC
 500 S EDWARDIA DR
 GREENSBORO, NC 27409

Sales Quote

Telephone: 800-845-0045

Sales Quote No.	623945
Customer No.	EXTERPD-CA

Bill To

Exeter Police Department
 100 N C St
 Exeter, CA 93221

Ship To

(For Pickup - FRES)
 FRESNO WAREHOUSE
 2550 S East Ave Ste 120
 Fresno, CA 93706

Contact: Lt. Rob Moore
 Telephone: 559.592.3103
 E-mail: rmoore@exeterpd.com

Contact: Andy Llanez
 Telephone: (559) 420-7057
 E-mail:

Quote Date	Ship Via	F.O.B.	Customer PO Number	Payment Method	
04/13/26	UPS GROUND FREIGHT	FREIGHT ON BOARD		NET30	
Entered By	Salesperson	Ordered By	Resale Number		
Patrick Hope	Pat Hope- Fresno				
Order Quantity	Approve Quantity	Tax	Item Number / Description	Unit Price	Extended Price
2	2	Y	ENGHNK06 Delivery Info: 710366 SOI 10FT REMOTE NODE HARNESS Warehouse: FRES	0.0000	0.00
1	1	N	INFO Inside Warehouse: FRES	0.0000	0.00
1	1	Y	7170-0734-04 GJ, CONSOLE PKG, 2020-23 PIU, SEE RMK TAB Warehouse: FRES 2020+ Ford Police Interceptor® Utility Low Profile Console Box with Cup Holder, Rear Armrest, and Mongoose® Kit Item #7170-0734-04 WEIGHT: 28.8 lbs / 13.06 kg HEIGHT: 19.1 in / 48.51 cm WIDTH: 8.98 in / 22.8 cm LENGTH: 26 in / 66.0 cm PACKAGE INCLUDES THE FOLLOWING: 7160-0846 DUAL CUP HOLDER, 7160-1334 VEHICLE SPECIFIC CONSOLE, 7160-0429 REAR MOUNTED ARMREST, & 7160-0220 MONGOOSE MOTION DEVISE. *****	0.0000	0.00
2	2	Y	MMSU-1 Delivery Info: O.H MAGNETIC MIC SINGLE UNIT CONVERSION KIT Warehouse: FRES	0.0000	0.00

Print Date	04/13/26
Print Time	05:53:22 PM
Page No.	5

DANA SAFETY SUPPLY, INC
 500 S EDWARDIA DR
 GREENSBORO, NC 27409

Sales Quote

Telephone: 800-845-0045

Sales Quote No.	623945
Customer No.	EXTERPD-CA

Bill To

Exeter Police Department
 100 N C St
 Exeter, CA 93221

Ship To

(For Pickup - FRES)
 FRESNO WAREHOUSE
 2550 S East Ave Ste 120
 Fresno, CA 93706

Contact: Lt. Rob Moore
 Telephone: 559.592.3103
 E-mail: rmoore@exeterpd.com

Contact: Andy Llanez
 Telephone: (559) 420-7057
 E-mail:

Quote Date	Ship Via	F.O.B.	Customer PO Number	Payment Method	
04/13/26	UPS GROUND FREIGHT	FREIGHT ON BOARD		NET30	
Entered By	Salesperson	Ordered By	Resale Number		
Patrick Hope	Pat Hope- Fresno				
Order Quantity	Approve Quantity	Tax	Item Number / Description	Unit Price	Extended Price
1	1	Y	GK10301S1U SMC T-RAIL DUAL WEAPON MT - 1 STD & 1 UNIV Warehouse: FRES Dual T-Rail Mount 1 Small 1 Universal XL With #2 Key Override	0.0000	0.00
1	1	Y	PK1130ITU20TM Setina 10XL Coated Polycarbonate Recessed (Tall Man) Warehouse: FRES	0.0000	0.00
1	1	Y	WK0514ITU20 SMC VERTICALSTEEL WINDOW BARS FOR 2020+ PIUT Warehouse: FRES Delivery Info: 710365	0.0000	0.00
1	1	Y	DK0100ITU20 SMC TPO POLYMER OVER MOLDED DOOR SKIN Warehouse: FRES Delivery Info: 710365	0.0000	0.00
1	1	Y	QK0635ITU25 SMC FULL REPLACEMENT TRANSPORT SEAT TPO PLASTIC Warehouse: FRES	0.0000	0.00

Print Date	04/13/26
Print Time	05:53:22 PM
Page No.	6

DANA SAFETY SUPPLY, INC
500 S EDWARDIA DR
GREENSBORO, NC 27409

Sales Quote

Telephone: 800-845-0045

Sales Quote No.	623945
Customer No.	EXTERPD-CA

Bill To

Exeter Police Department
 100 N C St
 Exeter, CA 93221

Ship To

(For Pickup - FRES)
 FRESNO WAREHOUSE
 2550 S East Ave Ste 120
 Fresno, CA 93706

Contact: Lt. Rob Moore
Telephone: 559.592.3103
E-mail: rmoore@exeterpd.com

Contact: Andy Llanez
Telephone: (559) 420-7057
E-mail:

Quote Date	Ship Via	F.O.B.	Customer PO Number	Payment Method	
04/13/26	UPS GROUND FREIGHT	FREIGHT ON BOARD		NET30	
Entered By	Salesperson	Ordered By	Resale Number		
Patrick Hope	Pat Hope- Fresno				
Order Quantity	Approve Quantity	Tax	Item Number / Description	Unit Price	Extended Price
2	2	Y	EBSDL0002-D Delivery Info: 710366 SOI, OBSERVE, SMALL FORM DOME LIGHT, 3", R/W Warehouse: FRES obSERVE+ Dome Light - 3" Round, Dual Color - Red/White 1) above console 1) in PT area	0.0000	0.00
1	1	Y	TK0233ITU20 SMC CARGO BOX Warehouse: FRES	0.0000	0.00
1	1	Y	TPA9289 SMC CARGO BOX SLIDING RADIO TRAY (TRN) Warehouse: FRES RADIO TRAY FOR CARGO BOX WITH NO LOCK ***** *DO NOT USE RADIO TRAY WITH ULTIMATE K9. RADIO TRAY BLOCKS SPARE TIRE*	0.0000	0.00
1	1	N	INFO Circuit Protection Warehouse: FRES	0.0000	0.00
1	1	Y	4703-100B Delivery Info: O.H Egis Circuit Breaker, Surface Mount, 100 Amp Warehouse: FRES	0.0000	0.00

Print Date	04/13/26
Print Time	05:53:22 PM
Page No.	7

DANA SAFETY SUPPLY, INC
500 S EDWARDIA DR
GREENSBORO, NC 27409

Sales Quote

Telephone: 800-845-0045

Sales Quote No.	623945
Customer No.	EXTERPD-CA

Bill To

Exeter Police Department
 100 N C St
 Exeter, CA 93221

Ship To

(For Pickup - FRES)
 FRESNO WAREHOUSE
 2550 S East Ave Ste 120
 Fresno, CA 93706

Contact: Lt. Rob Moore
Telephone: 559.592.3103
E-mail: rmoore@exeterpd.com

Contact: Andy Llanez
Telephone: (559) 420-7057
E-mail:

Quote Date	Ship Via	F.O.B.	Customer PO Number	Payment Method	
04/13/26	UPS GROUND FREIGHT	FREIGHT ON BOARD		NET30	
Entered By	Salesperson	Ordered By	Resale Number		
Patrick Hope	Pat Hope- Fresno				
Order Quantity	Approve Quantity	Tax	Item Number / Description	Unit Price	Extended Price
1	1	Y	8025B Delivery Info: O.H EGIS RT FUSE BLOCK 6 POS W/GROUND & LED IND., BULK Warehouse: FRES	0.0000	0.00
1	1	Y	8026B Delivery Info: O.H EGIS RT FUSE BLOCK 12-POS, W/ GROUND & LED INDICAT Warehouse: FRES	0.0000	0.00
1	1	Y	8020-1034B Delivery Info: O.H EGIS CUSTOM LABEL SET, CALIFORNIA SPEC Warehouse: FRES	0.0000	0.00
1	1	Y	7616-2001B Delivery Info: O.H EGIS DUAL TIME DELAY RELAY W/FULL HARNESS Warehouse: FRES	0.0000	0.00
1	1	N	INFO Customer Supplied Equipment Warehouse: FRES customer supplied parts are: - 1 x Modem w/ antenna & cable(s) - 1 x radio (remote head, brain, cabling, antenna, speaker) - 1x cradle or docking station	0.0000	0.00

Print Date	04/13/26
Print Time	05:53:22 PM
Page No.	8

DANA SAFETY SUPPLY, INC
 500 S EDWARDIA DR
 GREENSBORO, NC 27409

Sales Quote

Telephone: 800-845-0045

Sales Quote No.	623945
Customer No.	EXTERPD-CA

Bill To

Exeter Police Department
 100 N C St
 Exeter, CA 93221

Ship To

(For Pickup - FRES)
 FRESNO WAREHOUSE
 2550 S East Ave Ste 120
 Fresno, CA 93706

Contact: Lt. Rob Moore
 Telephone: 559.592.3103
 E-mail: rmoore@exeterpd.com

Contact: Andy Llanez
 Telephone: (559) 420-7057
 E-mail:

Quote Date	Ship Via	F.O.B.	Customer PO Number	Payment Method
04/13/26	UPS GROUND FREIGHT	FREIGHT ON BOARD		NET30
Entered By		Salesperson	Ordered By	Resale Number
Patrick Hope		Pat Hope- Fresno		

Order Quantity	Approve Quantity	Tax	Item Number / Description	Unit Price	Extended Price
1	1	Y	INSTALL KIT MISC INSTALLATION SUPPLIES I.E. Warehouse: FRES LOOM, WIRE, HARDWARE, CONNECTORS, ETC *****	800.0000	800.00
1	1	Y	INSTALL DSS INSTALLATION OF EQUIPMENT Warehouse: FRES	8,000.0000	8,000.00

Approved By: _____
 Approve All Items & Quantities
Quote Good for 30 Days

Print Date	04/13/26
Print Time	05:53:22 PM
Page No.	9

Subtotal	25,769.00
Freight	350.00
8.750 % Sales Tax	2,285.41
Order Total	28,404.41

By accepting this quote/order, the customer expressly acknowledges and agrees that to the extent not expressly prohibited by law, and except to the extent arising from or relating to the gross negligence or willful misconduct of DSS, its agents or its employees, DSS shall not be liable to the customer, or any third party, for any damage to the vehicle/products resulting from or arising out of any ACTS OF GOD, including without limitation, any fires, floods, earthquakes, tornados, hail or similar weather events.

County of Tulare IT Radio Comm.

5957 S. Mooney Blvd Ste. 2270
 Visalia, CA 93277
 559-622-7150 Fax: 559-737-4552

Quoted:	1/28/2026
Service Quote #:	20261002
Page:	1

Ship To:
Sheriff, Full patrol install 001-240-2550-9318 833 S. Akers Visalia, CA 93277 USA

Manufacturer:
Model:
Serial Number:
Alternate ID:
Reference:
Mileage:

Phone: 559-687-7001	Alternate Phone:	Terms:				
Service Rep: JVELA	Cust PO: Exeter Patrol Quote	Status: OPEN				
Valid Through: 2/27/2026						
Job #	Stock Code	Description	Indications/Work Performed	Quantity	Price	Extended

1	Technician:	Quote for Exeter Patrol Full build. Includes cages, console, code 3 equipment, gun-racks, siren speaker, and wiring harness. Sublet is for incidental expenses.				
	LABOR			55.00	105.00	5,775.00
	324/ES100CU	ES100C 100 Watt black compact speaker		1.00	297.00	297.00
	34-572	SPDT switch on-on screw terminals (3) 20		1.00	6.02	6.02
	382/C-ARM-103	havis arm rst		1.00	126.50	126.50
	382/C-VS-1210-INUT	Vehicle-Specific 22" Angled Console for		1.00	417.84	417.84
	382/CUP2-1001	Dual cup holder for console.		1.00	57.75	57.75
	382/PKG-KBM-1001	premium keyboard mount		1.00	731.50	731.50
	544/MMSU-1	Magnetic Microphone Clip		15.00	47.80	717.00
	5601	Miniaturized Power Tamer 30 amp.		1.00	98.95	98.95
	5EXHNP4P24-BL-R-BE	Cat 5 cable blue		15.00	0.23	3.45
	825/BK2019ITU20	PB450L4 Alum Bumper Ion LED*2020 PI		1.00	940.50	940.50
	825/GK11191B1S	dual vertical blac-rac and shot-gun		1.00	830.50	830.50
	825/PK0369ITU20TM	8VSRP Coated Poly Partition Tall Man2020		1.00	797.50	797.50
	825/QK0635ITU25	rear plastic seat and partition		1.00	1,370.33	1,370.33
	974/C399C399PCCTL7	whelen cencom core		1.00	1,117.05	1,117.05
	974/IB8DEDE	48" Duo wecan Liberty II		1.00	2,261.05	2,261.05
	AMZ-PI-DUAL-A/C-USE	power inverter (new-bigger)		1.00	31.89	31.89
	AT8X8RCSC-24	8 position RJ45 plug for solid wire conductor		6.00	0.34	2.04
	ATO 20	20 amp blade fuse,automotive		1.00	0.29	0.29
	ATO 7 1/2	FUSE		2.00	0.26	0.52
	MBD	NMO coax assembly w/17' teflon coax - no		1.00	42.15	42.15
	PL16 PK	Wire, Pink 16 ga. stranded		20.00	0.36	7.20
	PL16 PR	Wire, Purple 16 ga. stranded		20.00	0.36	7.20
	PL16 RD	Wire, Red 16 ga. stranded		20.00	0.36	7.20
	PL16 WH	Wire, White 16 ga. stranded		40.00	0.36	14.40
	PL16BK-500	16 gauge black stranded wire		20.00	0.36	7.20
	PL16GR	16 gauge stranded wire, green color		20.00	0.36	7.20
	PL16OR	16 gauge stranded wire, Orange color; also		20.00	0.36	7.20
	PL16YE	16 gauge stranded wire, yellow color		20.00	0.36	7.20
	PL20BL-500	20 gauge blue wire		20.00	0.23	4.60
	PL20BLK	Wire, Black 20 ga. stranded		20.00	0.06	1.20
	PL20GR	20 gauge wire, green color		20.00	0.07	1.40
	PL20OR	Wire, Orange 20 ga. stranded		20.00	0.07	1.40
	PL20WH	Wire, White 20 ga. stranded		20.00	0.06	1.20
	PL20YE	Wire, Yellow, 20 ga. stranded		20.00	0.06	1.20
	QWB450	Quarter wave antenna - Black		1.00	13.11	13.11

County of Tulare IT Radio Comm.

5957 S. Mooney Blvd Ste. 2270
 Visalia, CA 93277
 559-622-7150 Fax: 559-737-4552

Quoted:	1/28/2026
Service Quote #:	20261002
Page:	2

Ship To:
Sheriff, Full patrol install 001-240-2550-9318 833 S. Akers Visalia, CA 93277 USA

Manufacturer:
Model:
Serial Number:
Alternate ID:
Reference:
Mileage:

Phone: 559-687-7001 Alternate Phone: Terms:

Service Rep: JVELA Cust PO: Exeter Patrol Quote Status: OPEN Valid Through: 2/27/2026

Job #	Stock Code	Description	Indications/Work Performed	Quantity	Price	Extended
	REL-50	Bosch Relay 50AMP, 5 Pole		4.00	7.65	30.60
	RFU600-1	Mini UHF male connector for RG58AU /		1.00	1.90	1.90

Total Parts:	9,971.24	Total Labor:	5,775.00	Total Sublet:	100.00	Total Disposal:	0.00
				Pickup/Delivery:	0.00	Service Call:	0.00
						SubTotal:	15,846.24
						Tax:	847.56
						Shipping:	0.00
						Total:	16,693.80



Agenda Item Staff Report

Agenda Item Number:

J.1.

Meeting Date:

April 28, 2026

Wording for Agenda:

Consideration of Proposed Active Transportation Project on South E Street and Approval of Resolution No. 2026-13, A Resolution of the City Council of the City of Exeter, Authorizing the City Administrator to Utilize up to \$2,000,000 in Measure R Transit/Bike/Environmental Mitigation Funds Programmed to the City of Exeter for the E Street Active Transportation and ADA Improvements Project and Authorizing the City Engineer to Commence Design of the Project.

For action by:

City Council

Regular Session:

Consent Calendar

Regular Item

Public Hearing

Review:

City Administrator
(Initials Required)

J.R.

Submitting Department:

Engineering

Contact Name:

Javier Andrade, City Engineer

Department Recommendation:

Staff recommends that the City Council consider the proposed active transportation project on South E Street, adopt Resolution No. 2026-13, authorizing the City Administrator to utilize up to \$2,000,000 in Measure R Transit/Bike/Environmental Mitigation funds programmed to the City of Exeter for the E Street Active Transportation Project and ADA Improvements Project, and authorizing the City Engineer to commence the design phase of the Project.

Background & Summary:

Staff is requesting that the City Council consider a proposed active transportation project to enhance the pedestrian connection between downtown Exeter and City Park. The Project is proposed to construct a Class I trail along E Street, replace deteriorated and non-compliant sidewalk around the adjacent City park, and evaluate the addition of pedestrian-scale lighting to improve safety and usability of the park and trail.

This would include concrete improvements along South E Street between Pine Street and East Cedar Street, around City Park, and a trail through City Park. If approved, the City Engineer will begin preliminary design providing improvement options to the City Council. After receiving feedback from the City Council on the proposed plans, the City Engineer will complete the design and prepare the bid documents for the project. The current budget is proposed at \$2,000,000 based on the current funding available, the budget will be adjusted based on the estimated cost of improvements included in the final design.

Project Description:

The E Street Active Transportation and ADA Improvements Project consists of three primary elements:

- Class I multi-use trail along E Street — a dedicated, separated path for pedestrians, designed to Caltrans Highway Design Manual Chapter 1000 standards.
- Sidewalk replacement around the adjacent City park — removal and replacement of deteriorated and non-ADA-compliant sidewalk, together with upgraded curb ramps and pedestrian transitions as needed.
- Evaluation and potential installation of park and trail lighting — a pedestrian-scale lighting assessment to identify opportunities to improve visibility, safety, and after-hours use of the park and trail corridor. Inclusion of lighting in the final scope will be confirmed during preliminary engineering based on need, feasibility, and budget.

The Project is consistent with the City's Complete Streets with ADA Compliance and Active Transportation Safety Enhancement Grant study, the Caltrans State Route 65 Multi-Modal Corridor Study (February 2025), the TCAG Regional Active Transportation Plan, and the TCAG Regional Transportation Plan / Sustainable Communities Strategy. It will improve connectivity and accessibility for residents.

Phased Engineering Approach:

To responsibly scope and price the Project before committing the full design budget, the engineering work is proposed to be carried out in two phases:

Phase 1 – Preliminary Engineering (\$22,000). The City Engineer will use a portion of the engineering budget to develop a preliminary design concept for the trail, sidewalk replacement, and lighting evaluation; confirm scope and alignment; and prepare a preliminary opinion of probable construction cost. Staff will return to the City Council with the preliminary concept and associated pricing for review and direction prior to proceeding to final design.

Phase 2 – Final Design and Bid Documents (\$138,000). Upon Council direction, the City Engineer will use the remaining engineering budget to complete final design and prepare bid-ready construction documents for the Project. Construction management and construction will follow under the Project budget.

This phased approach gives the City Council an opportunity to confirm scope, cost, and priorities (including whether lighting is added to the final scope) before the majority of the engineering budget is expended.

Project Budget:

The \$2,000,000 Project budget is allocated substantially as follows, subject to refinement through the design process:

Phase	Percentage	Amount
Preliminary Engineering (concept, cost opinion, return to Council)	1.1%	\$22,000
Final Design and Bid Documents	6.9%	\$138,000
Construction Management	8%	\$160,000
Construction	84%	\$1,680,000
TOTAL	100%	\$2,000,000

The percentages for engineering and construction management are consistent with typical industry practice for projects of this scope.

Funding for the project in the amount of \$2,000,000 is available from Measure R Transit/Bike/Environmental Mitigation funds. These funds were programmed to the City of Exeter through the Tulare County Transportation Authority’s (TCTA) approval of 2024 Measure R Strategic Work Plan (SWP) Amendment No. 5 on October 20, 2025, which reallocated \$16,000,000 in previously programmed funds from the retired Measure R project category.

Adoption of this Resolution will authorize the City Administrator to utilize the \$2,000,000 programmed to the City and direct the City Engineer to begin design of the Project, allowing the City to move forward with the identified active transportation priority.

Measure R is a half-cent transportation sales tax approved by the voters of Tulare County in November 2006. It is administered by the Tulare County Association of Governments (TCAG), which sits as the Tulare County Transportation Authority (TCTA) when acting on Measure R matters. Measure R revenues are distributed under an Expenditure Plan that allocates 50 percent to Regional Projects, 35 percent to Local Programs, 14 percent to Transit/Bike/Environmental programs, and 1 percent to Administration and Planning.

Applying the \$2,000,000 programmed to the City toward the E Street Trail Project is consistent with the purpose of the Measure R Transit/Bike/Environmental Mitigation Plan

Fiscal Impact:

The total programmed amount is \$2,000,000, funded entirely from TCAG Measure R Transit/Bike/Environmental Mitigation funds programmed to the City of Exeter through 2024 Measure R Strategic Work Plan Amendment No. 5 (adopted October 20, 2025). No impact to

the City's General Fund is anticipated. Expenditure of funds will be made in accordance with Measure R program requirements, including any required Measure R funding agreement with TCAG and quarterly Measure R reporting.

Prior City Council Actions:

None associated with this action.

Attachments:

- Resolution No. 2026-13

Recommended motion to be made by the City Council:

I move to adopt Resolution No. 2026-13, A Resolution of the City Council of the City of Exeter, authorizing the City Administrator to utilize up to \$2,000,000 in TCAG Measure R Transit/Bike/Environmental Mitigation funds programmed to the City of Exeter for the E Street Trail Construction and ADA Improvements Project, and authorizing the City Engineer to commence design of the Project.

RESOLUTION NO. 2026-13

A RESOLUTION OF THE CITY COUNCIL OF THE CITY OF EXETER AUTHORIZING THE CITY ADMINISTRATOR TO UTILIZE \$2,000,000 IN TCAG MEASURE R TRANSIT/BIKE/ENVIRONMENTAL MITIGATION FUNDS PROGRAMMED TO THE CITY OF EXETER FOR THE E STREET ACTIVE TRANSPORTATION CONSTRUCTION AND ADA IMPROVEMENTS PROJECT AND AUTHORIZING THE CITY ENGINEER TO COMMENCE DESIGN OF THE PROJECT

WHEREAS, on November 7, 2006, the voters of Tulare County approved Measure R, a one-half cent transportation sales tax administered by the Tulare County Association of Governments (TCAG), sitting as the Tulare County Transportation Authority (TCTA), through 2037, with revenues distributed in accordance with an Expenditure Plan that includes Regional Projects (50%), Local Programs (35%), Transit/Bike/Environmental programs (14%), and Administration and Planning (1%); and

WHEREAS, the Measure R Transit/Bike/Environmental Mitigation Plan historically included \$16,000,000 programmed for a regional bicycle and pedestrian project identified as “K Road to Exeter”; and

WHEREAS, on October 20, 2025, the Tulare County Transportation Authority unanimously adopted a Resolution approving 2024 Measure R Strategic Work Plan (SWP) Amendment No. 5, which reallocated the \$16,000,000 previously programmed for the “K Road to Exeter” project as follows: \$2,000,000 to the City of Exeter, \$2,000,000 to the City of Farmersville, \$2,000,000 to the County of Tulare, \$8,000,000 to the City of Visalia for the Green Belt Bike/Pedestrian Trail, and \$2,000,000 held as undesignated funds for future Bike and Pedestrian priority projects; and

WHEREAS, through the Tulare County Transportation Authority’s adoption of 2024 Measure R SWP Amendment No. 5, the sum of \$2,000,000 has been programmed to the City of Exeter from the Measure R Transit/Bike/Environmental Mitigation Plan for use on a high-priority bicycle and pedestrian project within the City; and

WHEREAS, the E Street Active Transportation Construction and ADA Improvements Project is a high-priority active transportation investment consistent with the City of Exeter’s Complete Streets with ADA Compliance and Active Transportation Safety Enhancement Grant study, the Caltrans State Route 65 Multi-Modal Corridor Study dated February 2025, the TCAG Regional Active Transportation Plan (RATP), and the TCAG Regional Transportation Plan / Sustainable Communities Strategy (RTP/SCS); and

WHEREAS, the E Street Active transportation Project will provide a Class I multi-use trail and associated ADA-compliant pedestrian and curb-ramp improvements that will close existing gaps in the City’s pedestrian and bicycle network, improve safety and connectivity for residents including those residing in disadvantaged neighborhoods, and advance the City’s and the region’s active transportation goals; and

WHEREAS, utilizing the \$2,000,000 programmed to the City of Exeter for the E Street Active transportation Project is consistent with the purpose of the Measure R Transit/Bike/Environmental Mitigation Plan, responds to a documented community need, and will position the City to leverage these local Measure R dollars as matching funds for future state Active Transportation Program (ATP) and federal funding applications; and

WHEREAS, the City Council of the City of Exeter has reviewed the staff report and supporting documentation and finds that adoption of this Resolution is in the best interest of the public health, safety, and welfare of the residents of the City of Exeter.

NOW, THEREFORE, BE IT RESOLVED, that the City Council of the City of Exeter does hereby authorize and direct the following:

Section 1. The City Administrator is hereby authorized to utilize \$2,000,000 (Two Million Dollars) of TCAG Measure R Transit/Bike/Environmental Mitigation funds programmed to the City of Exeter through the Tulare County Transportation Authority's adoption of 2024 Measure R Strategic Work Plan Amendment No. 5 on October 20, 2025, for the E Street Active transportation Construction and ADA Improvements Project.

Section 2. The \$2,000,000 shall be budgeted substantially as follows: eight percent (8%) for engineering and design, equal to \$160,000; eight percent (8%) for construction management, equal to \$160,000; and the remaining eighty-four percent (84%) for construction, equal to \$1,680,000; subject to refinement through the design process.

Section 3. The City Engineer is hereby authorized to commence the design phase of the E Street Trail Construction and ADA Improvements Project upon adoption of this Resolution.

Section 4. The City Administrator, or designee, is hereby authorized to execute any Measure R funding agreement, amendments, certifications, and related documents required by TCAG or the TCTA to effectuate the purposes of this Resolution, subject to review and approval as to form by the City Attorney.

Section 5. City staff shall provide the reports required by the Measure R program, including quarterly Measure R reporting to TCAG.

Section 6. This Resolution shall take effect immediately upon its adoption.

PASSED AND ADOPTED by the City Council of the City of Exeter this 28th day of April, 2026 by the following vote:

AYES:

NOES:

ABSTAIN:

ABSENT:

Jacob Johnson, Mayor

ATTEST:

Francesca Quintana, City Clerk



Agenda Item Staff Report

Agenda Item Number:

J.2.

Meeting Date:

April 28, 2026

Wording for Agenda:

Consider Adoption of Resolution No. 2026-14, A Resolution of the City Council of the City of Exeter, Appointing a CalPERS Retired Annuitant to Serve as a Records Clerk on a Temporary Basis.

Submitting Department:

Administration and Police

Contact Name:

Francesca Quintana, City Clerk/Human Resources Manager
Rob Schimpf, Chief of Police

Department Recommendation:

Staff recommends that the City Council adopt Resolution No. 2026-14, appointing Rick Grimsley, a CalPERS retired annuitant, to perform Records Clerk duties on a temporary hourly basis to provide support with records management and evidence handling functions.

Summary:

The City has identified a need for additional support within the Police Department to assist with records management and evidence handling functions. These duties are critical to maintaining compliance with records retention requirements, supporting Public Records Act requests, and ensuring the proper organization, tracking, and storage of City records and evidence.

Historically, the City has not had a position solely dedicated to evidence management, and these responsibilities have been distributed among existing staff. As operational demands have increased, this approach has created challenges in maintaining consistent and efficient records and evidence management practices.

For action by:

City Council

Regular Session:

Consent Calendar

Regular Item

Public Hearing

Review:

City Administrator
(Initials Required)

 J.R.

To address this need, staff is recommending the temporary appointment of a retired annuitant with prior experience and familiarity with police operations to provide focused support in the Records Clerk role.

Rick Grimsley is a CalPERS retired annuitant with relevant experience and knowledge of City and Police operations. His background will allow him to provide immediate assistance with records organization, evidence tracking, and administrative support, helping ensure compliance and continuity of operations.

Under California Public Employees' Retirement System (CalPERS) regulations, Government Code Section 21221 allows CalPERS retirees to be employed by a CalPERS agency on a temporary basis to perform work of a limited duration requiring specialized skills or to prevent the stoppage of public business. Such employment must not exceed 960 hours in a fiscal year, and the retiree may not receive benefits or compensation in lieu of benefits.

Additionally, Government Code Section 7522.56 requires that post-retirement employment of a CalPERS retiree be approved by the governing body of the employer in a public meeting.

If Resolution No. 2026-14, is approved, Mr. Grimsley will serve as a Records Clerk on a temporary hourly basis, assisting with records and evidence management and providing administrative support. This appointment will help improve the City's ability to manage records and evidence effectively.

Fiscal Impact:

Funding for this temporary appointment has been included in the proposed biennial budget under temporary salaries within the Police Department fund. Compensation for the retired annuitant will remain within the limits established by CalPERS and will not exceed 960 hours in a fiscal year. The rate of pay will be \$25.97 with no other benefits provided.

Prior City Council Actions:

None associated with this action.

Attachments:

- Records Clerk Job Description
- CalPERS Circular Letter
- Resolution No. 2026-14

Recommended motion to be made by the City Council:

I move to adopt Resolution No. 2026-14, appointing Rick Grimsley as a CalPERS retired annuitant to serve as a Records Clerk on a temporary basis.



CLASSIFICATION: NON-SWORN

RECORDS CLERK

DEFINITION:

Under general supervision, performs a variety of administrative, clerical, office and customer service duties of moderate difficulty in the Police Department including the maintenance, processing, and distribution of police records. Performs related responsibilities as required.

Incumbents perform a variety of record keeping, administrative, clerical, office support, and customer service work including providing general information to the public, collecting fees, processing and distribution of police records, typing of forms, memoranda, correspondence and reports; assists callers and visitors; maintains records and other documents; learns policies, procedures and work methods associated with assigned duties; performs other related duties as required. Positions in this class work in an established framework in accordance with established rules and procedures and is distinguished from the Senior Clerk Dispatcher in that the later has broader responsibility for training and oversight of assigned staff and performs the most complex work within the function.

SUPERVISION RECEIVED AND EXERCISED:

Receives direct or general supervision from assigned supervisory or management personnel.

ESSENTIAL DUTIES AND RESPONSIBILITIES:

Management reserves the right to add, modify, change, or rescind the work assignments of different positions and to make reasonable accommodations so that qualified employees can perform the essential functions of the job.

- Performs a variety of routine administrative and clerical processes which requires a general knowledge and understanding of department policies and procedures.
- Acts as receptionist by screening calls and visitors, referring inquiries as appropriate and responding to complaints and information requests.
- Maintains and updates records according to established policies and procedures, including indexing a wide variety of violations and notifications, tracking and filing reports, and redacting confidential information when required; purges records and files as required.
- Assembles and compiles information for a variety of departmental, State mandated, and statistical reports, including verifying accuracy and completion of reports and maintaining files.
- Types, formats, edits, proofreads, files, gathers, follows-up on and compiles correspondence, reports, forms, and a variety of other documents related to the functions of department or division.

Records Clerk
Page 1 of 3

- Performs data entry; updates and maintains various records, files, and books.
- Receives payments from customers, balances cash drawer, maintains records and submits for deposit cash received daily.
- Keeps current on legislative changes regarding record release, retention and sealing of police records.
- Process legal requests including court orders and subpoenas.
- Prepares, copies, collates, and distributes a variety of documents, including agendas, bid packages, contracts, informational packets, and specifications; ensures proper filing of copies in department or central files.
- May issue and process a variety of permits, applications, licenses, and other forms.
- Receives, opens, time stamps, sorts and distributes incoming and interdepartmental mail; prepares and distributes outgoing mail.
- Operates computer terminal, utilizing word processing and other software programs.
- Monitors and orders, office, and other related supplies.
- Coordinates calendars and makes meeting arrangements, and schedule meetings.
- May assist with department payroll and accounts payable processing.
- Performs related duties as assigned.

QUALIFICATIONS:

Knowledge of:

- Basic functions, principals, and practices of law enforcement agencies.
- Applicable Federal, State, and local codes, regulations, policies, technical processes, and procedures.
- Techniques, methods, and processes of record management and retrieval.
- English usage, grammar, spelling, vocabulary, and punctuation.
- Modern office methods and procedures including word processing applications.
- Principles of business letter writing.
- Basic principles of record keeping, cash handling, business arithmetic, and basic statistical techniques.
- Computer applications related to work, including word processing software, and record keeping.
- Terminology and procedures used in public safety dispatching.
- Filing systems and procedures.
- Techniques for dealing effectively and providing a high level of customer service to the public, vendors, contractors, and City staff, in person and over the telephone.

Skill in:

- Public contact.
- Report preparation.

Ability to:

- Learn, interpret, apply, and explain rules, policies, procedures, laws, codes, and regulations.
- Learn police terminology and law enforcement codes.
- Organize, research, and maintain technical and administrative files
- Exercise independent judgment in solving clerical and administrative problems.
- Interact with the public and internal customers on a regular basis
- Maintain confidentiality.

- Transcribe dictation from notes or dictating machine.
- Type at a rate of speed sufficient to meet the requirements of the position (45 wpm).
- Follow oral and written directions.
- Develop and maintain effective working relationships.
- Operate standard office equipment, including computer terminal plus word processing knowledge.
- Respond to and effectively prioritize multiple phone calls and other requests for service.
- Organize own work, set priorities, meet critical deadlines with minimal supervision.
- Learn and understand the organization and operation of the City and of outside agencies as necessary to assume assigned responsibilities.
- File materials alphabetically, chronologically, and numerically.
- Use word-processing, database, spreadsheet, and software applications.
- Use tact, initiative, prudence and independent judgment within general policy, procedural, and legal guidelines.
- Pass stringent personal background investigation.

Licenses and Certifications:

- Possession of a valid and appropriate California's driver's license.
- Typing Certificate (45 wpm)

Education and Experience:

A combination of training and experience which would provide the required knowledge, skills, and abilities is qualifying. A typical way to obtain the required qualifications would be:

- Minimum: graduation from high school or GED.
- Equivalent to two years of increasingly responsible administrative, clerical and/or accounting experience.
- College level administrative, business and/or recordkeeping courses desirable.

PHYSICAL DEMANDS AND ENVIRONMENTAL ELEMENTS:

Must possess mobility to work in a standard office setting and use standard office equipment, including a computer; to operate a motor vehicle and to visit various City sites; vision to read printed materials and a computer screen; and hearing and speech to communicate in person, before groups and over the telephone. This is primarily a sedentary office classification although standing in work areas and walking between work areas may be required. Finger dexterity is needed to access, enter and retrieve data using a computer keyboard, typewriter keyboard or calculator and to operate standard office equipment. Positions in this classification have regular occasion to bend, stoop, kneel, reach, push and pull drawers open and closed to retrieve and file information. Employees must possess the ability to lift, carry, push, and pull materials and objects necessary to perform job functions.

Employees work in an office environment with moderate noise levels, controlled temperature conditions and no direct exposure to hazardous physical substances. Employees may interact with upset staff and/or public and private representatives in interpreting and enforcing departmental policies and procedures.



California Public Employees' Retirement System
P.O. Box 942715
Sacramento, CA 94229-2715
(888) CalPERS (or **888-225-7377**)
TTY: (877) 249-7442
www.calpers.ca.gov

Circular Letter: 200-053-16
Distribution: IV, V, VI, X, XII, XVI

Circular Letter

November 17, 2016

TO: **ALL CALPERS EMPLOYERS**

SUBJECT: **REQUIREMENTS FOR WORKING AFTER DISABILITY RETIREMENT
FOR A CALPERS EMPLOYER**

The purpose of this Circular Letter is to inform employers of the requirements for working after disability retirement for a CalPERS employer.

Government Code (G.C.) sections 7522.56, 7522.57, 21202, 21220, 21220.5, 21221(h), 21224, 21227, 21229, 21231 and 21232, provide the requirements for employment of a CalPERS retiree. A CalPERS disability/industrial disability retiree may work for a CalPERS employer, i.e., an employer who contracts with CalPERS for retirement benefits or a state agency, either in a retired annuitant position or in a permanent position with certain restrictions.

Requirements for Working as a Retired Annuitant

A retired annuitant position does not require CalPERS pre-approval; however, the position must be significantly different from the position which a retiree retired. The retired annuitant position should not include duties or activities that the retiree was previously restricted from performing at the time of his/her retirement.

1. Wait Period for Retirees

To be eligible for employment as a retired annuitant, all retirees must meet the following requirements to be eligible to work for a CalPERS employer:

- A. The bona fide separation requirement if younger than normal retirement age on retirement date.
- B. The 180-day wait period requirement or an allowable exception.

A. Bona Fide Separation Requirement

This bona fide separation in service is required of CalPERS by the Internal Revenue Code (IRC) to maintain our federal tax-qualified status. The only exception to the 60 calendar day separation is when a declared emergency as provided in G.C. section 8558 requires the employment of the retiree.

When the retiree is under his/her “normal retirement age” on the retirement date, employment cannot begin, even if an exception to the 180-day wait period applies, unless both of the following conditions are met:

- There is no verbal or written agreement to return to work, either as a retired annuitant or in a position under G.C. section 21232, between the member and the employer before the member retires, and
- There is a termination of employment (separation in service) for 60 calendar days between the retirement date and the date the retiree’s employment will begin.

B. 180-Day Wait Period Requirement

All employees retired January 1, 2013 and later must serve a 180-day wait period between the retirement date and the first day of post retirement employment. There are certain exceptions to this wait period. Please refer to the [Public Agency & Schools Reference Guide](#) or the [State Reference Guide](#) online for details and sample resolutions.

2. Types of Retired Annuitant Appointments

There are two types of retired annuitant appointments for public agency and school employers, “extra help” and “vacant position”. The retired annuitant employment requirements are the same for both. There are additional requirements for the vacant position appointment.

A. Extra Help Appointments:

- Limited Duration Work: The retiree has the skills needed to perform work of limited duration or the employment is needed during an emergency to prevent stoppage of public business.
- 960 Hour per Fiscal Year Limit: A retired annuitant can work no more than 960 hours in a fiscal year, July 1 - June 30, for employment with all CalPERS employers combined. There is no exception to this limit. The retiree and employer have equal responsibility to track the hours worked.
 - A CSU academic retiree may be employed in any fiscal year as a member of the CSU academic staff in a retired annuitant position not to exceed 960 hours for all employers or 50 percent of the hours the member was employed during the last fiscal year of service prior to retirement, whichever is less (G.C. sections 7522.56 and 21227).
- Pay Rate Only Compensation:
 - Extra Help Positions: the retiree can be paid no more than the maximum monthly base salary paid to other employees performing comparable duties as listed on the employer’s publicly available pay schedule divided by 173.333 to equal an hourly rate.
 - Vacant Position Appointments: the retiree can be paid no more than the maximum monthly base salary paid to other employees performing comparable duties as listed on the employer’s publicly available pay schedule for the vacant position divided by 173.333 to equal an hourly rate.

- No Benefits, Other Compensation: The retiree cannot receive any benefit, incentive, compensation in lieu of benefits, or be paid any other form of compensation in addition to the hourly pay rate. There are no exceptions.
- No Retirement Contributions: No retirement contributions are collected or paid for employed retirees. Only active members pay contributions.
- Payroll Reporting (for Public Agencies and Schools only): All retirees hired as retired annuitants must be enrolled in the CalPERS system and their payroll must be reported. See the "Payroll Reporting, Retired Annuitants" section of the Public Agency & Schools Reference Guide for information.

B. Vacant Position Appointments:

- All of the Extra Help Appointments retired annuitant requirements above apply to Vacant Position Appointments. A retiree can be appointed once as an interim or acting employee by the governing body of the employer to a vacant position during recruitment for a permanent replacement. This recruitment must be active and in place before the retiree is appointed. (G.C. sections 7522.56 and 21221(h)).

3. Unemployment Insurance Benefits And Retired Annuitant Employment

California law prohibits the reappointment of a retired annuitant by a CalPERS employer if, during the 12-month period prior to reappointment, the retiree received unemployment insurance compensation for prior retired annuitant employment with any public employer.

A retiree shall certify in writing to the employer upon accepting an offer of post-retirement employment that he or she is in compliance with this requirement.

Employers may require retirees to provide a current Unemployment Insurance Benefit (UIB) printout from the Employment Development Department (EDD) indicating whether or not he/she has collected unemployment insurance within the last 12 months to verify compliance. Please refer to the Public Agency & Schools Reference Guide or the State Reference Guide online for detail.

If a currently employed retiree is discovered to have received unemployment insurance compensation based on prior retired annuitant employment, the current employment must be terminated on the last day of the current pay period and the retiree shall not be eligible for reappointment by a CalPERS employer for 12 months following the termination of the current employment. A violation of this provision will not result in reinstatement from retirement, i.e., termination of retirement (G.C. Section 7522.56 (e) and 21224.)

Special Appointments - Retired Annuitant Requirements Do Not Apply

Information remains the same. Please refer to the [Public Agency & Schools Reference Guide](#) or the [State Reference Guide](#) online for detailed information.

Eligibility to Work for a CalPERS Employer in a Permanent Capacity after Disability Retirement

To be eligible for employment, a retiree must first meet the following requirements:

- The bona fide separation requirement, if applicable
- The 180-day wait period requirement or an allowable exception
- No receipt of unemployment insurance payments for previous retired annuitant employment 12 months before the appointment
- State Employer Civil Service Eligibility for employment with a state agency employer

CalPERS pre-approval is required for working in a permanent position (full-time or part-time) for a CalPERS employer without reinstatement. Such employment cannot begin prior to the Board's approval. The employment must meet the requirement in G.C. section 21232. In addition, the position should not include duties or activities that the retiree was previously restricted from performing at the time of his/her retirement. A retiree who is pre-approved to work under G.C. section 21232 shall not be concurrently employed as a retired annuitant. Violation of any of these requirements will result in reinstatement from disability/industrial disability retirement per G.C. sections 21220 & 21202.

G.C. section 21232 states, "On and after January 1, 2013, a person who has retired for disability and has not attained the mandatory age for retirement for persons in the employment in which he or she will be employed, and whom the board finds is not disabled for that employment, may be so employed by any employer without reinstatement from retirement if the position is not the position from which this person retired or a position in the same member classification. The person's disability retirement pension shall be reduced during this employment to an amount that, when added to the compensation received, equals the maximum compensation earnable by a person holding the position that he or she held at the time of retirement. This employment shall terminate upon the person's attainment of the mandatory retirement age for persons in that employment. A person employed under this section shall not be concurrently employed under this article."

Upon approval of the re-employment, the employer is required to enroll the retiree in my|CalPERS system. Public Agencies and schools are required to report payroll in my|CalPERS system. No retirement contributions are collected or paid for employed retirees. Only active members pay contributions. The retiree will be required to submit a copy of their first paystub and a copy of their W-2 annually, in January to CalPERS, as the disability retirement pension is subject to an earnings limit for as long as the employment continues.

If the retiree is to be promoted, demoted, lateral transferred, reclassified, changes job location, restarts a previously approved position or changes to a different employer, a new re-employment approval must be obtained prior to the position change, or the retiree may be subject to retroactive reinstatement from disability/industrial disability retirement and be liable for reimbursement of any retirement allowance paid.

For required CalPERS pre-approval documents please refer to the [Public Agency & Schools Reference Guide](#) or the [State Reference Guide](#) online.

Termination of Retirement Due To Unlawful Employment

Employers and retirees have equal responsibility to ensure any post-retirement employment is lawful. Employment that violates any of the retired annuitant requirements or the section 21232 requirements is unlawful employment. Unlawful employment results in reinstatement from retirement, i.e., termination of the retiree's monthly retirement allowance and any other post-retirement benefit.

When reinstated due to unlawful employment, the retiree is required to reimburse CalPERS for the retirement allowance received during the period of unlawful employment. Upon enrollment into active membership, the employee will pay member contributions plus interest to the employer for the period of unlawful employment. The employer will pay retroactive employer contributions plus interest and submit the member contributions thereby crediting the employee with service credit for the period of unlawful employment.

Independent Contractor Employment And Employment through a Third-Party Employer

Information remains the same. Please refer to the [Public Agency & Schools Reference Guide](#) or the [State Reference Guide](#) online for detailed information.

Other Resources

The Public Agency & Schools Reference Guide or the State Reference Guide, which is located on the [CalPERS website](#) contains information regarding requirements for working for other public retirement system or private sector after disability retirement.

If you have any questions, please call our CalPERS Customer Contact Center at **888 CalPERS** or **(888-225-7377)**.

Anthony Suine, Chief
Benefit Services Division

RESOLUTION NO. 2026-14

**A RESOLUTION OF THE CITY COUNCIL OF THE CITY OF EXETER APPOINTING
A CALPERS RETIRED ANNUITANT TO SERVE AS RECORDS CLERK ON A
TEMPORARY BASIS**

WHEREAS, the City of Exeter contracts with the California Public Employees' Retirement System (CalPERS) to provide retirement benefits for its eligible employees; and

WHEREAS, Government Code section 21221 authorizes a CalPERS agency to employ a CalPERS retiree on a temporary basis to perform work of a limited duration requiring specialized skills or to prevent the stoppage of public business; and

WHEREAS, Government Code section 7522.56 requires that post-retirement employment of a CalPERS retiree be approved by the governing body of the employer in a public meeting; and

WHEREAS, the City has identified a need for additional support in records management and administrative functions; and

WHEREAS, the City Council finds that the temporary appointment of a retired annuitant is necessary to ensure continuity of operations and to prevent the stoppage of public business; and

WHEREAS, Rick Grimsley is a CalPERS retired annuitant; and

WHEREAS, the City Council has reviewed and approves the appointment of Rick Grimsley to perform the duties of Records Clerk on a temporary basis; and

WHEREAS, the City Council and Rick Grimsley certify that he has not received any retirement-related incentive and has not received unemployment insurance benefits during the last twelve (12) months arising from post-retirement employment with a CalPERS agency; and

WHEREAS, this appointment shall not exceed 960 hours in a fiscal year, and Rick Grimsley shall receive no benefits or additional compensation beyond the hourly rate of \$25.97 per hour; and

NOW, THEREFORE, BE IT RESOLVED that the City Council of the City of Exeter hereby appoints Rick Grimsley as a CalPERS retired annuitant pursuant to Government Code sections 21221 and 7522.56 to serve as Records Clerk on a temporary basis.

PASSED AND ADOPTED by the City Council of the City of Exeter this 28th day of April, 2026 by the following vote:

AYES:

NOES:

ABSTAIN:

ABSENT:

Jacob Johnson, Mayor

Francesca Quintana, City Clerk